



DPW | SOLAR



PREFORMED LINE PRODUCTS



POWER-FAB CRS ASSEMBLY INSTRUCTIONS

**step-by-step
assembly and installation**

Part Number: 5805000, Rev H

CONTENTS

About the Product and these Instructions	1
CRS Parts Identification	2
Step 1: Layout and arrange Power Beams	3
Step 2: Splicing Power Beams	3
Step 3: Inserting EPDM Gaskets into Power Beams	3
Step 4: Pre-loading Track Bolts in N-S Power Beams	4
Step 5: Joining N-S and E-W Power Beams - Reference Planes	5
Step 6: Joining N-S and E-W Power Beams - Using Tie Plates	5
Step 7: About Front and Rear Tilt Bracket Spacer Jigs	8
Step 8: Installing Front and Rear Tilt Brackets	8
Step 9: Installing E-W Formed Aluminum Angles	12
Step 10: Installing Ballast Pans	13
Step 11: Attaching Wind Deflectors	15
Step 12: Weighting Ballast Pans	16
Step 13: Installing North-most Modules against Wind Deflectors	16
Step 14: Installing PV Modules	18

POWER-FAB[®] CRS (Commercial Racking System)

CAUTION:

Do not attempt to install the POWER-FAB CRS system on any roof with a pitch greater than 1/12 (approximately 5 degrees) as this could lead to a catastrophic structural failure and severe personal injury or death.

CAUTION:

Be certain that the tilt angle and corresponding ballast are carefully followed in accordance to the projects design specifications. Failure to do so could lead to catastrophic structural failure and severe personal injury or death.

WARNING:

Follow the procedures and precautions in these instructions carefully.

A few words about the product

The POWER-FAB CRS (Commercial Racking System) is a non-penetrating structure, i.e. the structure does not get screwed, bolted or otherwise fastened to the roof substrate. Instead, it is weighted (held in place) to the roof substrate using concrete-cap blocks as ballast.

In its standard configuration (ballast on the northern edge, southern edge and every other row in between) and in areas with a Class C exposure category, the CRS tilt angle of 5-degrees is rated for 130 MPH wind speeds while the 10-degree tilt is rated for 90 MPH. Steeper tilt angles and higher wind speeds are possible by adding extra ballast blocks.

CAUTION

The POWER-FAB CRS system is to be installed over *adhered* or *fixed roof surfaces* only. If additional roof protection materials, including slip sheets, drain mats or sacrificial layers, are added under the CRS structure, those materials must be *adhered* to the main roofing material and *trimmed* so no more than 6-inches of slip sheet, drain mat or other sacrificial material extends beyond the perimeter of the CRS rails and ballast trays.

If adhering of these materials is not possible, please contact DPW Solar engineering for additional review.

About these Assembly Instructions

These instructions...

- Are intended to be used by individuals with sufficient technical skills for the task. Knowledge and use of hand tools, measuring devices and torque values is also required.
- Include various precautions in the forms of Notes, Cautions, and Warnings. These are to assist in the assembly process and/or to draw attention to the fact that certain assembly steps may be dangerous and could cause serious personal injury and/or damage to components. Following the step-by-step procedures and these precautions should minimize the risk of any personal injury or damage to components while making the installation not only safe but an efficient process.

For questions on a specific installation please contact us at:

Phone: 800-260-3792

Email: info@power-fab.com

For DPW Solar approved Wiley Electronics grounding solutions, please visit www.we-llc.com

Required Tools

1/2 inch wrench or socket for 5/16 inch module clamp hardware

Torque wrench

Ratchet wrench

Ratchet extension bar

Framing square

Tape Measure

Utility Knife

Item	Description	Qty
1	Wind Deflector	Design Specific
2	Ballast Pan, set of (5/16" x 1-3/8") track bolts, flange nuts	Design Specific
3	3-Hole Tie Plate, set of (5/16" x 3/4") track bolt, flange nut	(2) E-W + (1) N-S
4	Power Beam	Design Specific
5	Rear Tilt Bracket, set of (5/16" x 3/4") track bolts, flange nuts	Design Specific
6	End-Clamp, (5/16" x *) bolt, lock & flat washer, nut	Design Specific
7	Mid-Clamp, (5/16" x *) bolt, lock & flat washer, nut	2 per 3/8" gap between modules
8	Front Tilt Bracket, set of (5/16" x 3/4") track bolts, flange nuts	Design Specific
9	Formed Aluminum Angle, set of (5/16" x 3/4") hex bolts, flange nuts	Design Specific
10	EPDM Rubber gasket	Design Specific
11	Side Splice Plate, set of (5/16" x 1-3/8") track bolt, flange nut	Design Specific
12	2-Hole Tie Plate, set of (5/16" x 3/4") track bolts, flange nuts	Design Specific

* Length is dependent on depth of PV Module frame.

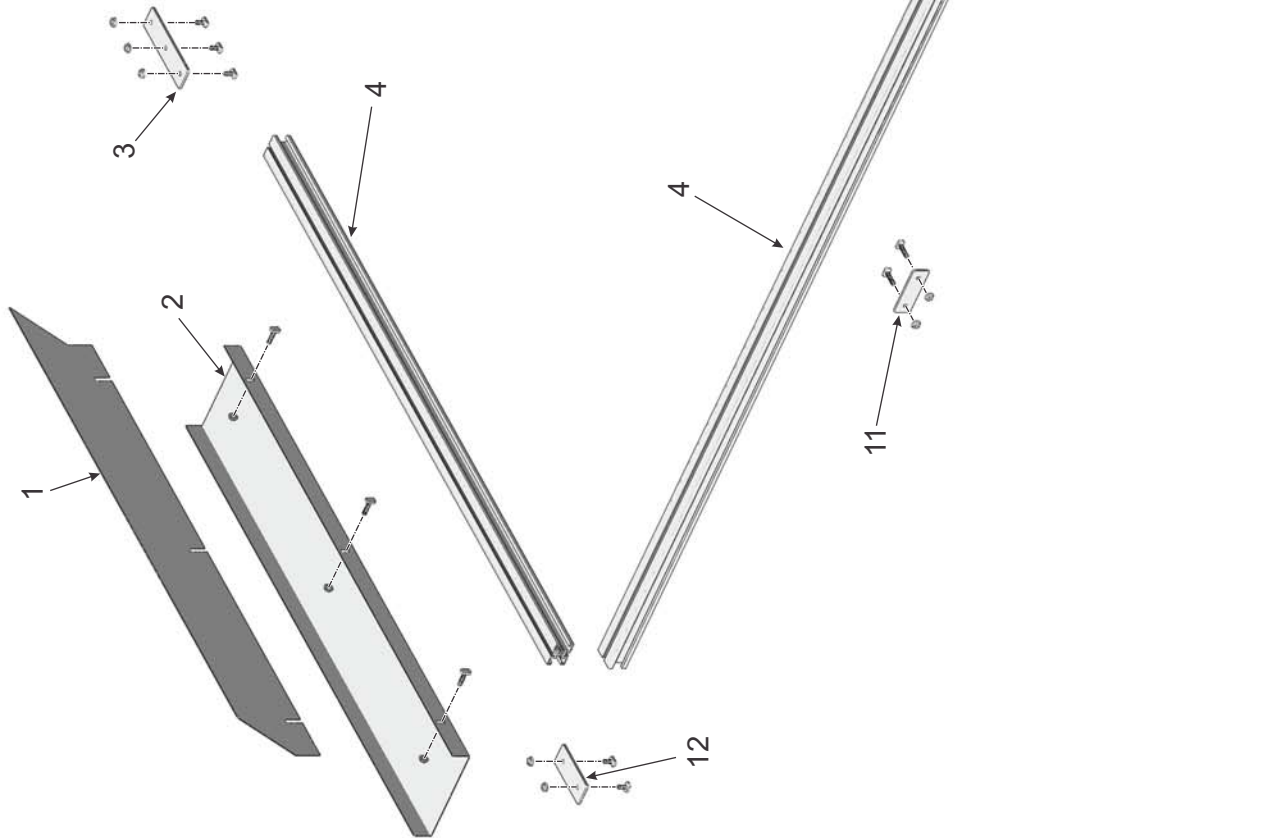

POWER-FAB CRS Parts Identification

Step 1: Layout and arrange the N-S and E-W Power Beams

Referring to the job specific drawings for placement, select and position all the N-S and E-W Power Beams in what will be roughly their assembled locations. Arranging these members now will greatly assist in the upcoming assembly steps.

Step 2: Splicing Power Beams

If any Power Beam exceeds 25 feet in length, it will require the use of a Side Splice Plate and butt joint to extend the length beyond 25 feet. Side Splice Plates are mounted on the sides of the Power Beam. The sub-steps below show how to install a Side Splice Plate. (See Figure 2-1)

- A. Insert two 5/16 x 1-3/8 inch Track Bolts into the ends along the sides of the Power Beams to be joined.
- B. Push the two Power Beams together to create a butt joint.
- C. Position the Side Splice Plate onto the Track Bolts centering it over the butt joint.
- D. Install the Flange Nuts onto the Track bolts and while holding the butt joint together, tighten the Flange Nuts and **Torque to 14-16 ft.-lbs.**

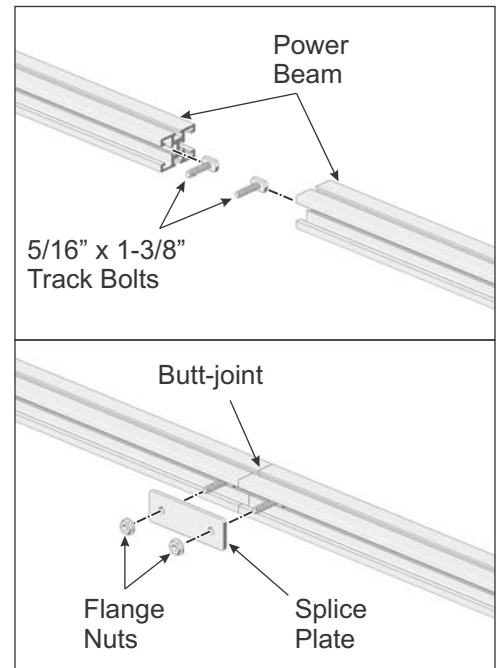

Figure 2-1: Splicing Power Beam with Splice Plate

Step 3: Inserting EPDM rubber gaskets into N-S Power Beams

Each of the N-S Power Beams requires EPDM gaskets. The gaskets are 48 inches long. These gaskets serve two purposes; they protect the roof surface and also provide additional friction between the CRS structure and roof surface. This additional friction helps keep the structure from shifting on the roof surface. Additionally, the gaskets create a gap between the Power Beams and the roof surface which allows water to drain from the roof.

- A. Matching the extrusion profiles, insert the EPDM gasket into the N-S Power Beams. (See Figure 3-1)

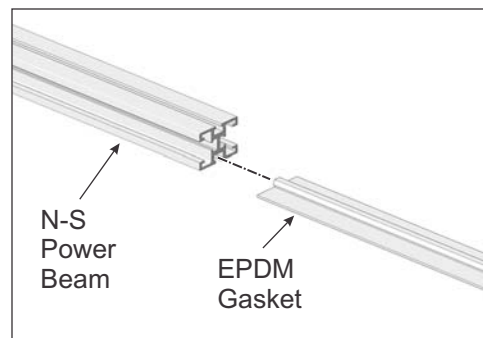

Figure 3-1: Inserting EPDM Gasket into N-S Power Beam

NOTE:

Do not install EPDM gaskets on E-W Power Beams.

- B. Insert an adequate amount of 48-inch gaskets into each N-S Power Beam while leaving a 6 to 8 inch gap between the gaskets. If necessary, cut the final gasket to length filling the balance of the Power Beam.
- C. Position the N-S Power Beams with the EPDM rubber gaskets resting on the roof surface. (See Figure 3-2)

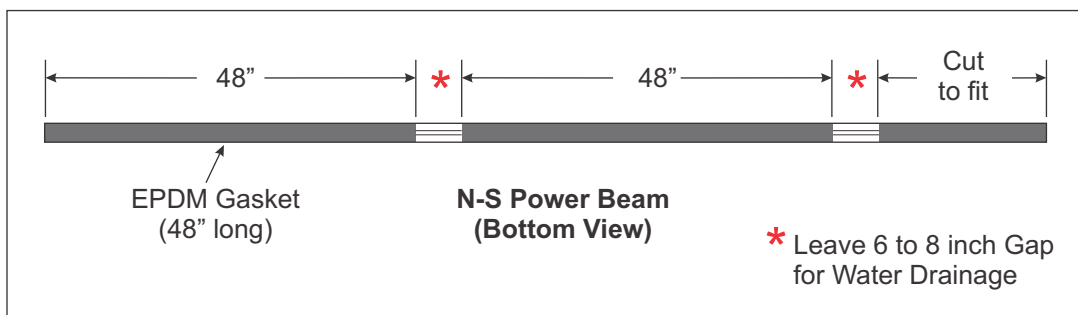

Figure 3-2: Arranging EPDM Gaskets on N-S Power Beam

Step 4: Pre-load Track Bolts into the N-S Power Beams

A design specific quantity of Track Bolts must be pre-loaded into the N-S Power Beams; this must be done before any further assembly takes place.

N-S Power Beam Track bolt quantities are job/design specific. The quantities are determined by the number of Tilt Brackets (Front and Back Tilt Brackets) to be mounted on the N-S Power Beams. Each Tilt Bracket requires two Track Bolts. Referring to sheet 1 of the job specific assembly drawings, count the number of Tilt Brackets for a given N-S Power Beam and multiply that quantity by two. Pre-load this quantity of 5/16 x 3/4 inch Track Bolts into the N-S Power Beam. (See Figure 4-1)

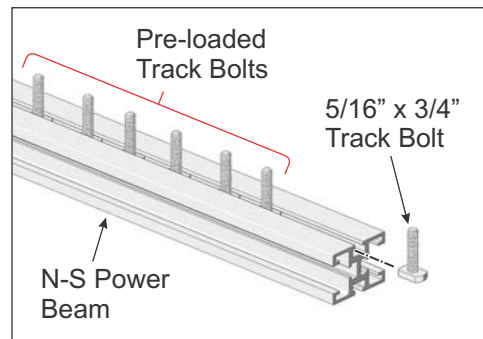

Figure 4-1: Pre-loading Track Bolts into N-S Power Beams

NOTE:

All necessary 5/16 x 3/4 inch Track Bolts must be pre-loaded into the N-S Power Beams before proceeding.

Step 5: Joining the N-S and E-W Power Beams – First, set up Reference Planes

NOTE:
Consistent squaring of the joints saves time and simplifies the assembly process.

In joining the Power Beams to one another it's best to set up **Reference Planes** that all subsequent joints will align to. This will vastly improve the ability to fit and align those components yet to be assembled.

Start at the Southwest corner joint and install a Front Module Tilt Bracket, joining the N-S Power Beam to the Southern-most E-W Power Beam. (See Figure 5-1)

- A. Line up the butt joint of the N-S and E-W Power Beams.
- B. Align the Front Module Tilt Bracket onto its respective Track Bolts (pre-loaded in the Power Beams) spanning the joint of the N-S and E-W Power Beams. Install Flange Nuts and finger tighten.
- C. Using a Framing Square, square-up the N-S and E-W Power Beam joint. Once the joint is square and butted tightly, tighten the Flange Nuts and **Torque to 14-16 ft.-lbs.**

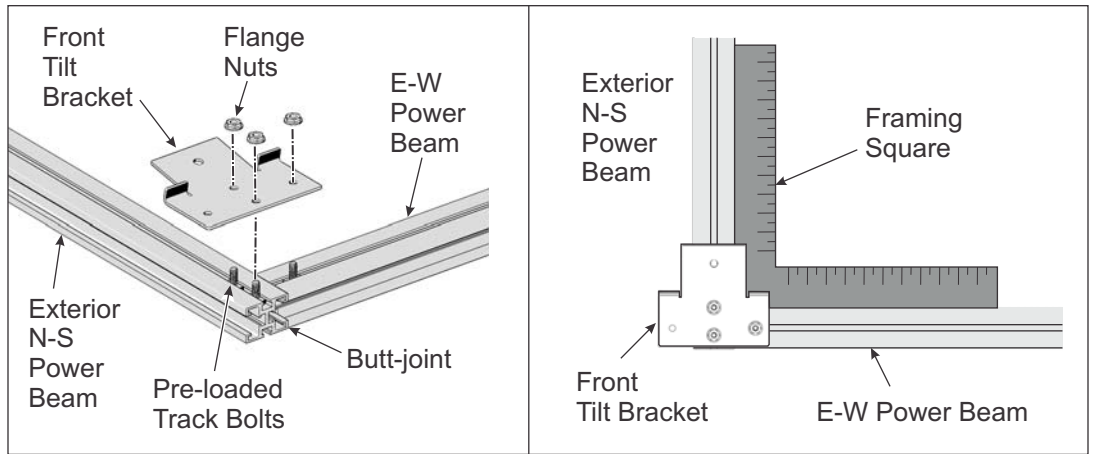
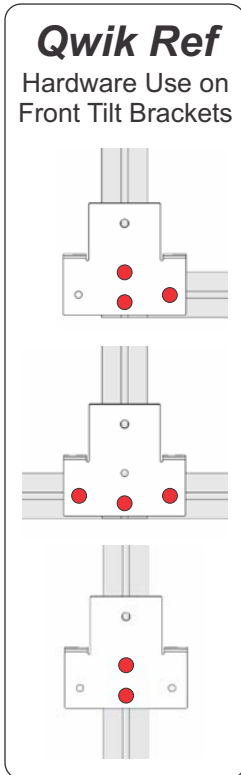

Figure 5-1: Establishing a Southwest Reference Plane by Joining N-S and E-W Power Beams with a Front Tilt Bracket

NOTE:
Be sure that the orientation of the Tilt Bracket is correct. Follow the instructions carefully.

Position this assembled Reference Plane as close as possible to its final southwest location with the Power Beams directed N-S and E-W.

With the Reference Plane established, build from it while installing the remaining N-S and E-W Power Beams keeping them square and true to the established Reference Plane.

Step 6: Joining the N-S and E-W Power Beams – Using Tie Plates and Front Tilt Brackets

N-S Power Beams are joined to E-W Power Beams using Front Module Tilt Brackets (on the south end), 2-Hole or 3-Hole Tie Plates (on the north end), Track Bolts and Flange Nuts. Be mindful in choosing the style of Tie Plate or Front Tilt Bracket, and follow the instructions carefully.

NOTE:

Squaring the corner joints now saves time as the assembly progresses. If the structural framework is not square and is skewed, it may be difficult to fit subsequent members or components.

- All Southern-most joints (corner or tee-joints) are joined using a Front Module Tilt Bracket.
- The Northern-most interior tee-joints (the intersection of one N-S Power Beam and two E-W Power Beams) are joined using a 3-Hole Splice Plate.
- The Northern-most corner joints (the intersection of one Exterior/Perimeter N-S Power Beam and one Exterior/Perimeter E-W Power Beam) are joined using a 2-Hole Splice Plate.

Using a Front Tilt Bracket on a south Tee-joint of two E-W Power Beams to a N-S Power Beam. (See Figure 6-1)

- Pre-load one each of the 5/16 x 3/4 inch Track Bolts into the work ends of the two E-W Power Beams.
- Install a Front Module Tilt Bracket onto the Track Bolts (pre-loaded in the Power Beams), spanning the joint of the N-S and E-W Power Beams. Install Flange Nuts and finger tighten.
- Using a Framing Square square-up the N-S and E-W Power Beam joint. Once the joint is square and butted tightly, tighten the Flange Nuts and **Torque to 14-16 ft.-lbs.**

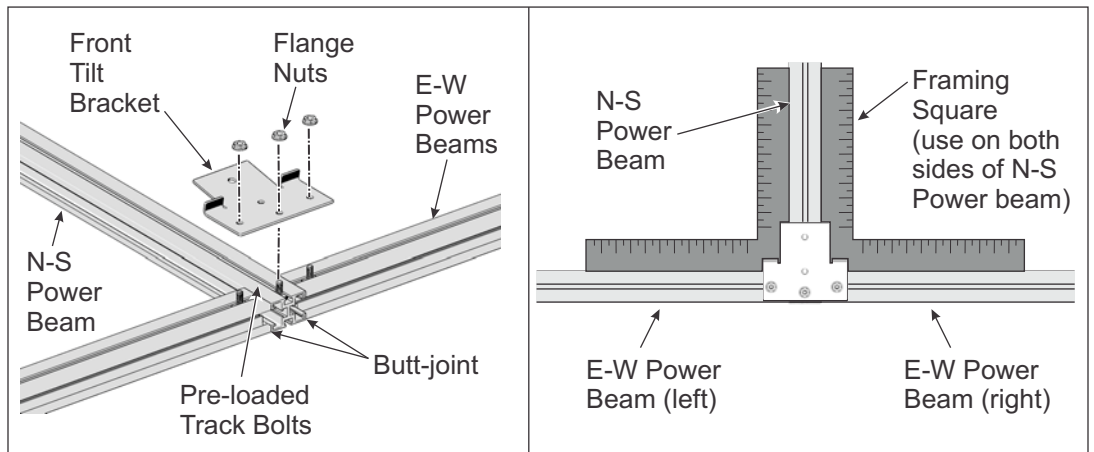
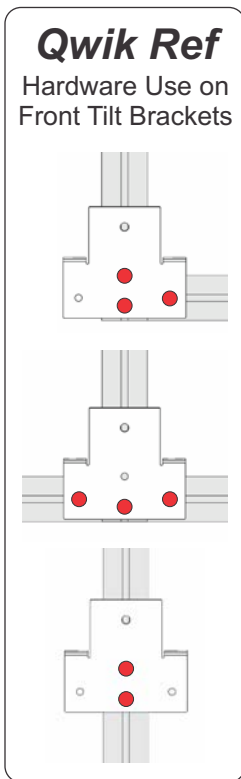

Figure 6-1: Using a Front Tilt Bracket on a south Tee-joint

Using a 3-Hole Tie Plate on a north Tee-joint of a N-S Power Beam to a E-W Power Beam.

- Pre-load one each of the 5/16 x 3/4 inch Track Bolts in the work ends of both of the E-W Power Beams and one in the N-S Power Beam.
- Install a 3-Hole Tie Plate onto its respective Track Bolts (previously installed in the Power Beams), spanning the joint of the N-S and E-W Power Beams. Install Flange Nuts and finger tighten (See Figure 6-2).
- Using a Framing Square, square-up the N-S and E-W Power Beam joint. Once the joint is square and butted tightly, tighten the Flange Nuts and **Torque to 14-16 ft.-lbs.**

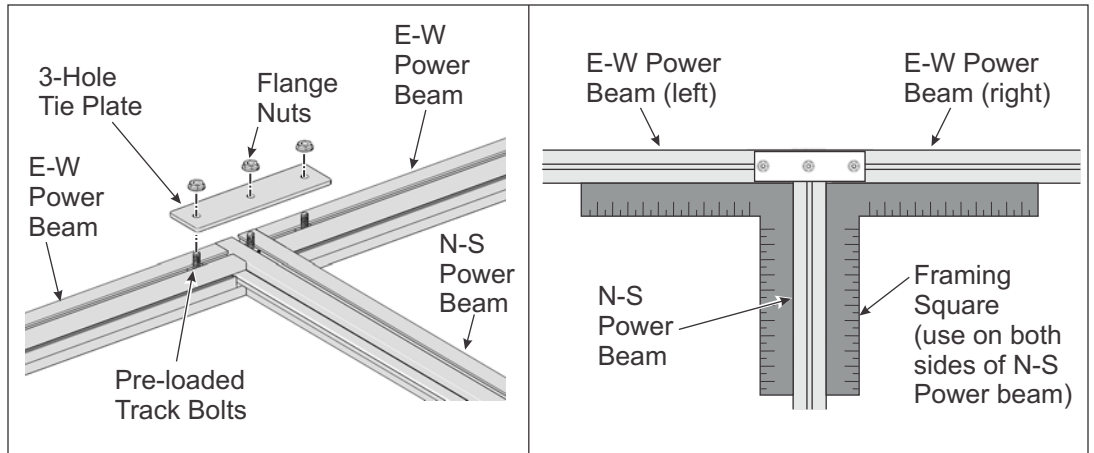

Figure 6-2: Using a 3-Hole Tie Plate on a north Tee-joint

Using a 2-Hole Tie Plate on a north Corner-joint of a N-S Power Beam to a E-W Power Beam. (See Figure 6-3)

- A. Pre-load one each of the 5/16 x 3/4 inch Track Bolts in the work ends of both the N-S and E-W Power Beams.
- B. Install a 2-Hole Tie Plate onto the Track Bolts spanning the joint of the N-S and E-W Power Beams. Install Flange Nuts and finger tighten.
- C. Using a Framing Square, square-up the N-S and E-W Power Beam joint. Once the joint is square and butted tightly, tighten the Flange Nuts and **Torque to 14-16 ft.-lbs.**

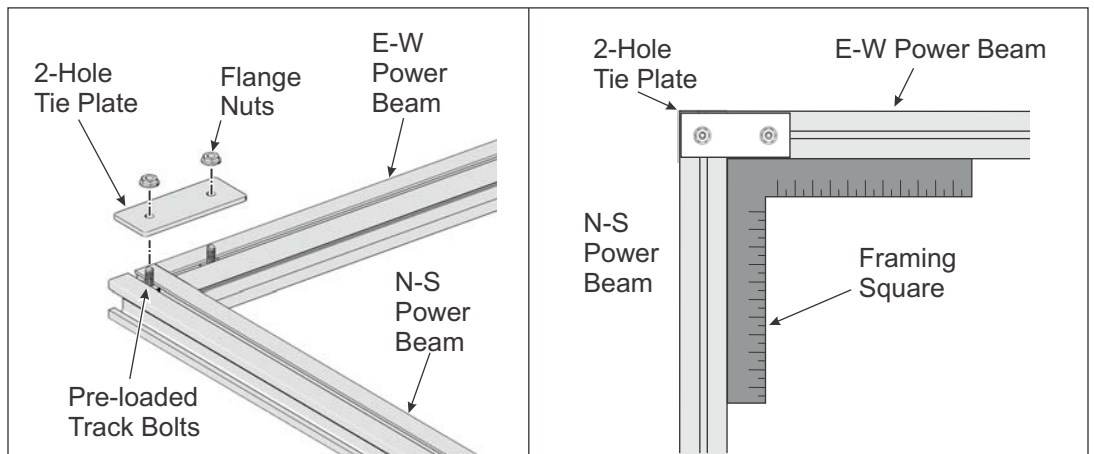

Figure 6-3: Using a 2-Hole Tie Plate on a north corner joint

Repeat these steps working towards the east until all N-S Power Rails are joined, forming the base Power Beam structure.

Step 7: About Front and Rear Tilt Brackets and Spacer Jigs

Front and Rear Tilt Brackets are installed along the N-S Power Beams and provide the necessary tilt angle for the PV Modules. The Tilt Brackets also include anchoring points for securing the PV Modules using Mid or End Clamps and standard hardware. In addition, the E-W Formed Aluminum Angles are attached to the Front Tilt Brackets.

The quantity, placement and spacing of the Tilt Brackets is job specific. Proper spacing of the Tilt Brackets along the Power Beams is accomplished using the job specific Module Spacer Jigs provided along with the project materials. There are two types of Module Spacer Jigs; the *Inter Module Spacer Jig* which measures the span *between* PV Modules and the *Under Module Spacer Jig* which measures the span *under* the PV Module and establishes the distance between Front and Rear Tilt Brackets. (See Figure 7-1)

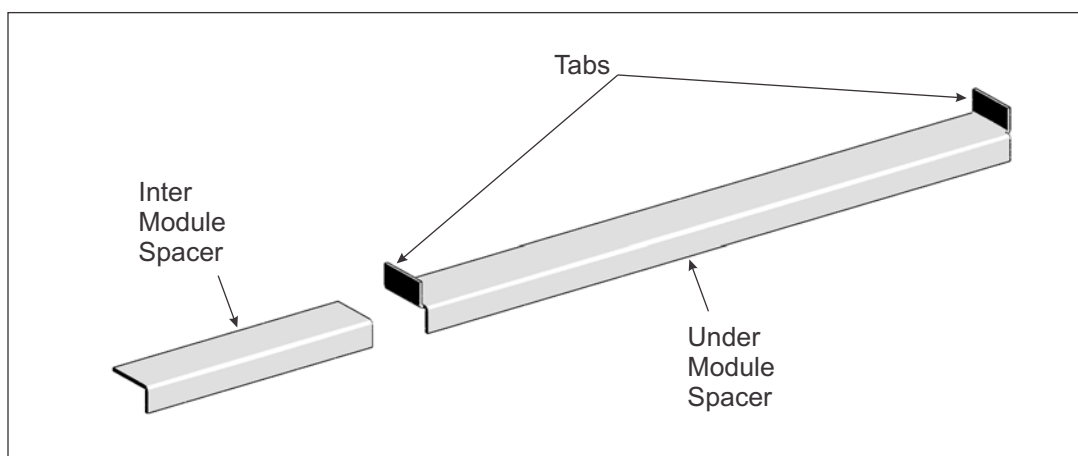

Figure 7-1: Under and Inter Module Spacer Jigs

Step 8: Installing Front and Rear Tilt Brackets along the N-S Power Beams and Test Fitting PV Modules

It is recommended to initially install a minimum of three sets of PV Module Tilt Brackets to be familiar with using the Spacing Jigs and to also test fit three PV Modules. This practice helps to prevent missteps that could lead to significant re-work of the installation process.

NOTE:
The Under Module Spacer Jig has the up-turned tabs.

For the test, arrange and install the Tilt Brackets so that one PV Module is in the southwest-most position, one is to its north and one to its east. The steps below describe installation of the quantity of Tilt Brackets needed for this test. After the Tilt Brackets are installed, test fit the three PV Modules to make sure they align properly with the Tilt Bracket placement and that all attaching hardware installs properly.

Start at the southwest-most E-W Power Beam where the Front Module Tilt Brackets were previously installed (See Figure 8-1).

- A. Apply the Under Module Spacer Jig to the west-most or exterior N-S Power Beam to set the span from the previously installed Front Module Tilt Bracket and the next to be installed Rear Module Tilt Bracket.

- B. Align and orient the Rear Module Tilt Bracket onto the next in-line or corresponding Track Bolts previously installed in the N-S Power Beam.
- C. Position the Under Module Spacer Jig against the previously installed Front Module Tilt Bracket. Slide and butt the Rear Module Tilt Bracket (and its Track Bolts) against the opposite end of the Under Module Spacer Jig. Hold the Tilt Bracket in place and install Flange Nuts, **Torque to 14-16 ft.-lbs.**

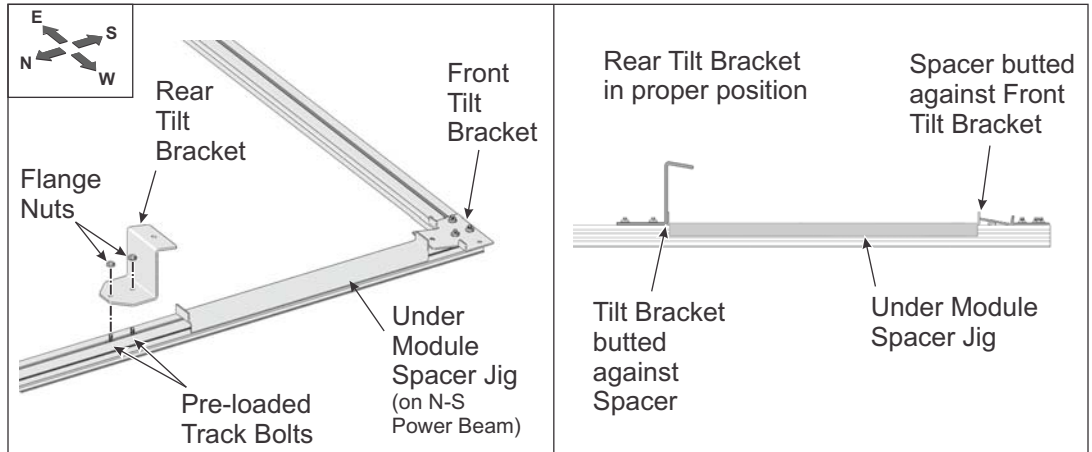

Figure 8-1: Installing a Rear Tilt Bracket

- D. On the same N-S Power Beam install the next Front Module Tilt Bracket. Align and orient the Front Module Tilt Bracket onto the next in-line or corresponding Track Bolts previously installed in the N-S Power Beam. (See Figure 8-2)
- E. Position the Inter Module Spacer Jig against the previously installed Rear Module Tilt Bracket. Slide and butt the Front Module Tilt Bracket (and its Track Bolts) against the opposite end of the Inter Module Spacer Jig. Hold the Tilt Bracket in place and install Flange Nuts, **Torque to 14-16 ft.-lbs.**

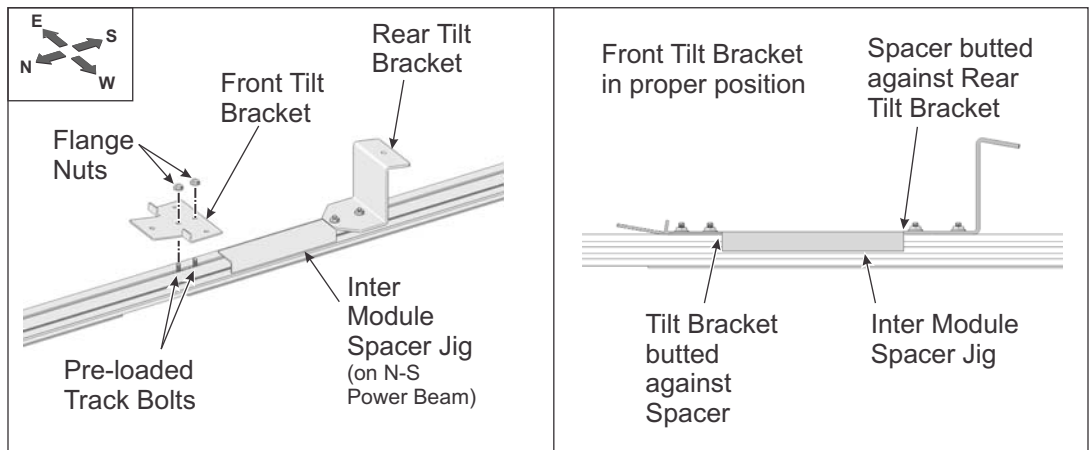
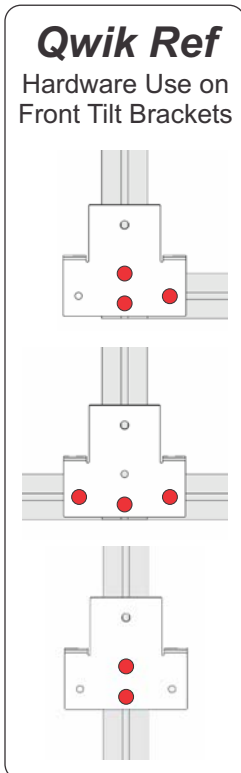

Figure 8-2: Installing a Front Tilt Bracket

- F. Move east to adjacent interior N-S Power Beams and repeat sub-steps A thru E above, installing the appropriate number of Tilt Brackets to test fit three PV Modules.

NOTE:

Test fitting the PV Modules prior to installing all Tilt Brackets can save time.

NOTE:

Step 13 contains complete instructions on installing PV Modules.

CAUTION:

This is a two-person activity. PV Modules are heavy and should be carefully placed and aligned on top of the Tilt Brackets. Failure to use two people could lead to physical injury and/or damaged components.

Now test fit three N-S PV Modules onto the Tilt Brackets starting with the southwest-most Module.

- G. Position PV Module onto the southwest-most Front Tilt Brackets. Allow Module frame to rest against the tabs of the Front Tilt Brackets. Lower the rear of the Module and rest it on top of the Rear Module Tilt Brackets. (See Figure 8-3)

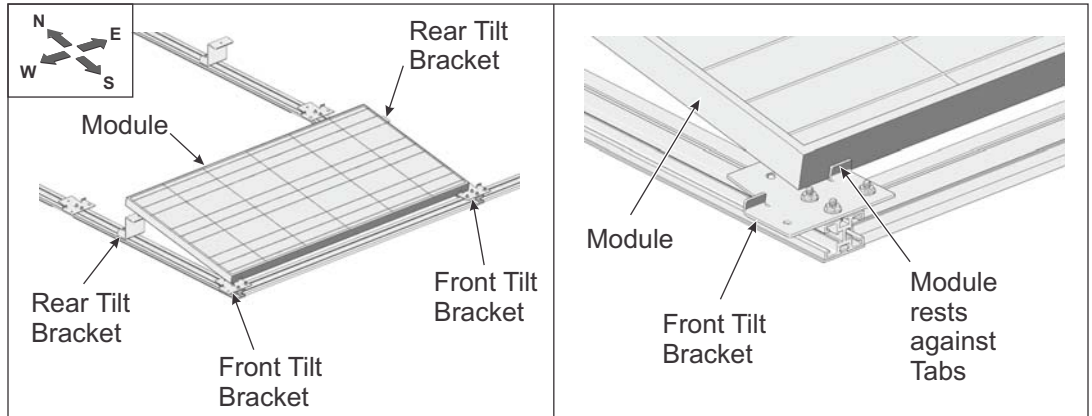

Figure 8-3: Installing PV Modules onto Tilt Brackets

- H. Using a tape measure, center the Module (from east to west) over the Tilt Brackets. Keep its frame pushed against the Front Tilt Bracket Tabs. (See Figure 8-4)
- I. Repeat sub-steps G and H above to install one Module directly to the north and one Module directly to the east of this first test Module.

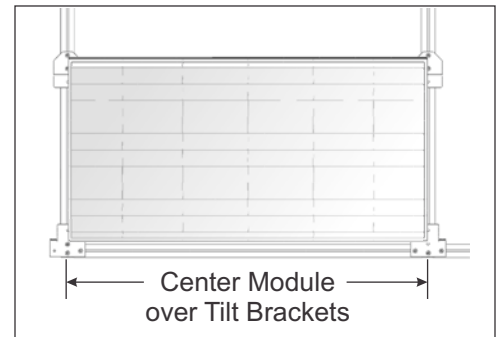

Figure 8-4: Centering the Module over the Tilt Brackets

Secure the outside edge of the Module with End Clamps. Install two End Clamps per Module, one on each of the exterior Tilt Brackets (Front and Rear). (See Figure 8-5)

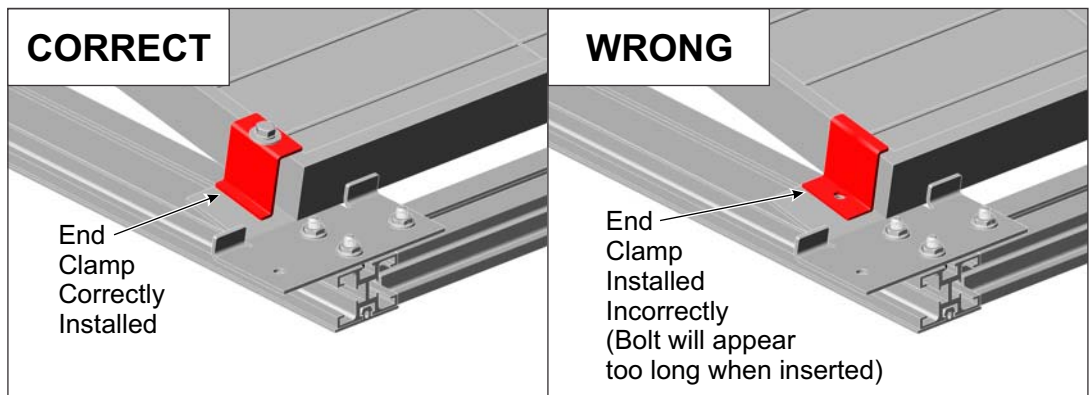

Figure 8-5: Correct and Wrong methods of installing Standard End Clamp

CAUTION: Finger Tightening End and Mid Clamps is a temporary procedure for test fitting Modules. Permanently installed Modules must be tightened to specific torque values.

- J. Insert one 5/16 x XX inch bolt (length is dependent on thickness of PV Module) along with flat and lock washers through the End Clamp and thread into the Tilt Bracket. For now, finger-tighten the bolt as this is only a test run. (See Figures 8-6 and 8-7)

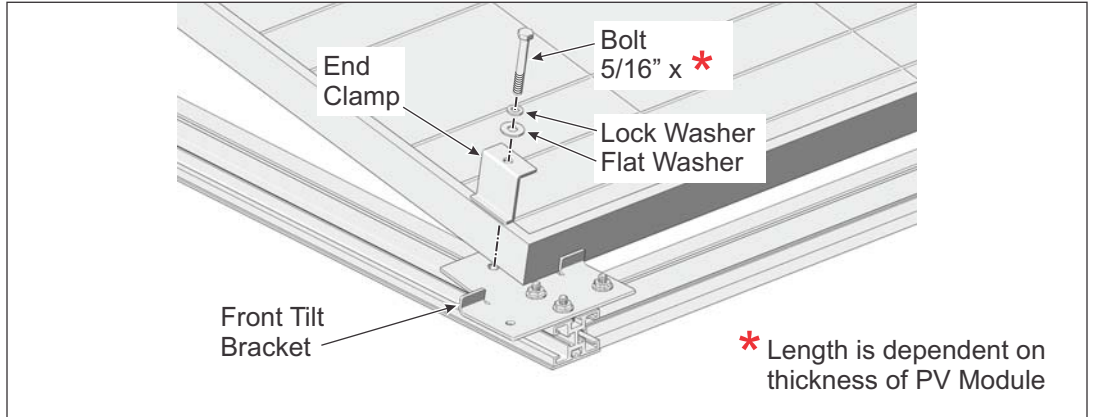

Figure 8-6: Installing an End Clamp on a Front Tilt Bracket

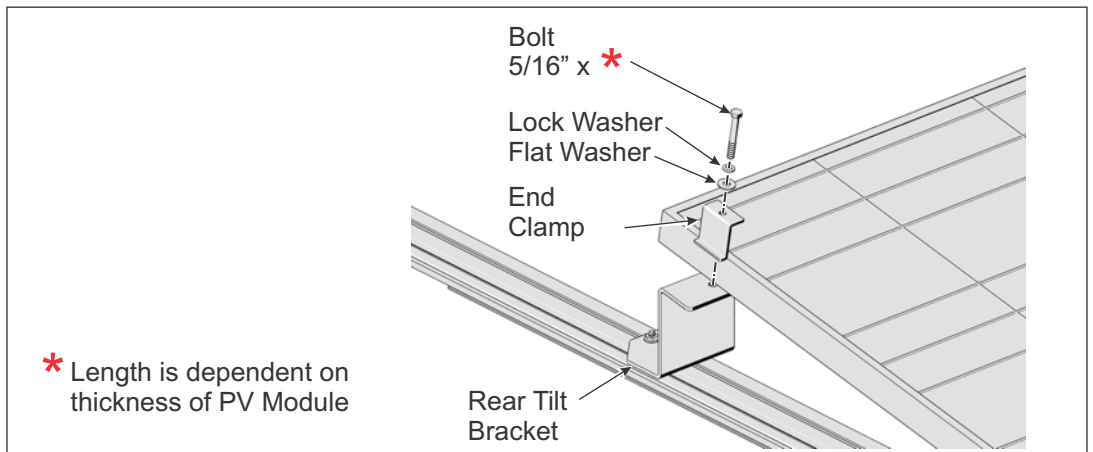

Figure 8-7: Installing an End Clamp on a Rear Tilt Bracket

Secure the inside Module edges with Mid Clamps. Install two Mid Clamps per Module one on each of the interior Tilt Brackets (Front and Rear) between two E-W Modules. (See Figures 8-8 and 8-9)

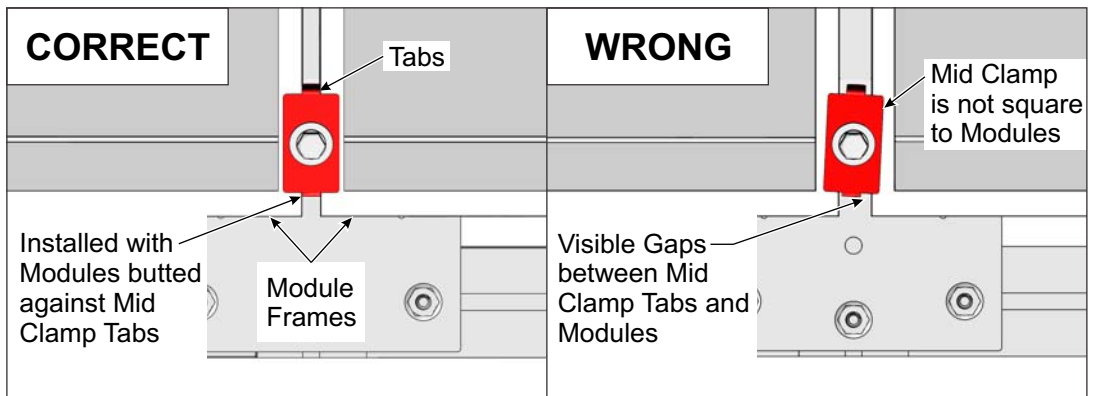

Figure 8-8: Correct and Wrong methods of installing Standard Mid Clamp

CAUTION:
Finger Tightening End and Mid Clamps is a temporary procedure for test fitting Modules. Permanently installed Modules must be tightened to specific torque values.

- K. Insert one 5/16 x XX inch bolt (length is dependent on thickness of PV Module) with lock and flat washers through the Mid Clamp and thread into the Tilt Bracket. Be sure that the tabs of the Mid Clamps rest between the two Modules and the Modules are butted up against the Mid Clamp tabs (see figure 8-8). For now, finger-tighten the bolts as this is a test run. (See Figure 8-9)

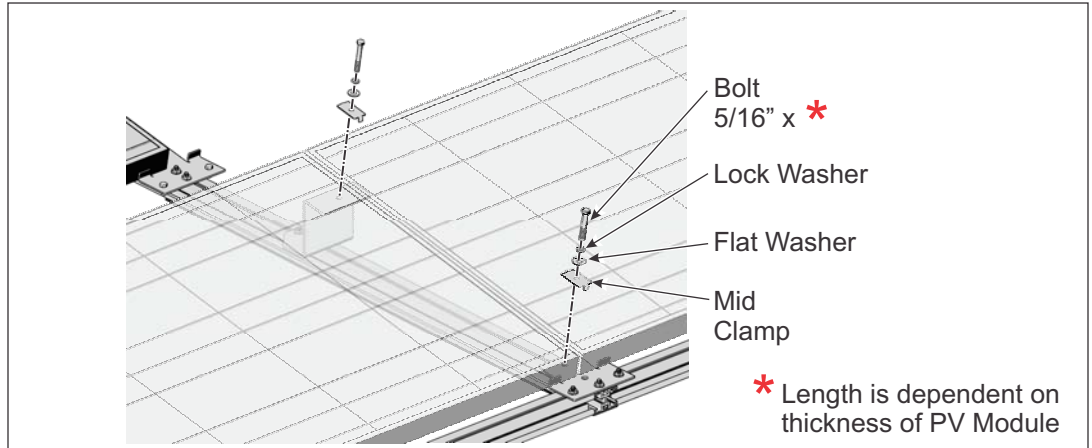

Figure 8-9: Installing Mid Clamps into Front and Rear Tilt Brackets

WARNING:
To prevent damage to the Modules used in the test fitting, remove and set aside the modules before proceeding with the assembly.

If the Modules do not fit correctly, the Tilt Bracket Spacer Jigs may not have been properly used. Be certain that the Under-Module Spacer (the one with the up-turned tabs) was used to create the space “under” the Modules while the Inter-Module Spacer was used to create the space “between” the adjacent N-S Modules.

Once the PV Modules fit, uninstall and remove the Modules before proceeding with the assembly. This will help prevent any accidental damage to the Modules.

Repeat sub-steps 8A-E to install all remaining Tilt Brackets alternating from Front to Rear Tilt Brackets and working north on each of the N-S Power Beams.

Step 9: Installing the E-W Formed Aluminum Angles

The E-W Formed Aluminum Angles are used only in the intermediate positions. They are attached to the interior Front Module Tilt Brackets using 5/16 x 3/4 inch hex bolts and Flange Nuts.

E-W Formed Aluminum Angles have mounting holes on both planes. One set of holes attach the Aluminum Angles to the Front Module Tilt Brackets while the other set is used to attach Ballast Pans to the Angle itself. Be sure the orientation of each Angle is consistent and the plane with the Ballast Pan mounting holes is oriented with its face to the south.

- A. Starting at the first set of interior Front Module Tilt Brackets, install an E-W Formed Aluminum Angle by aligning its mounting hole with the mounting hole of the Front Module Tilt Bracket (See Figure 9-1).
- B. Secure each end of the Formed Aluminum Angle with a 5/16 x 3/4 inch hex bolt. Install Flange Nuts on each bolt and tighten. **Torque to 14-16 ft.-lbs.**

Repeat these steps to install remaining E-W Formed Aluminum Angles.

NOTE:
Make certain that the Aluminum Angles are installed in the correct orientation. The face with the Ballast Pan mounting holes must be oriented to the south.

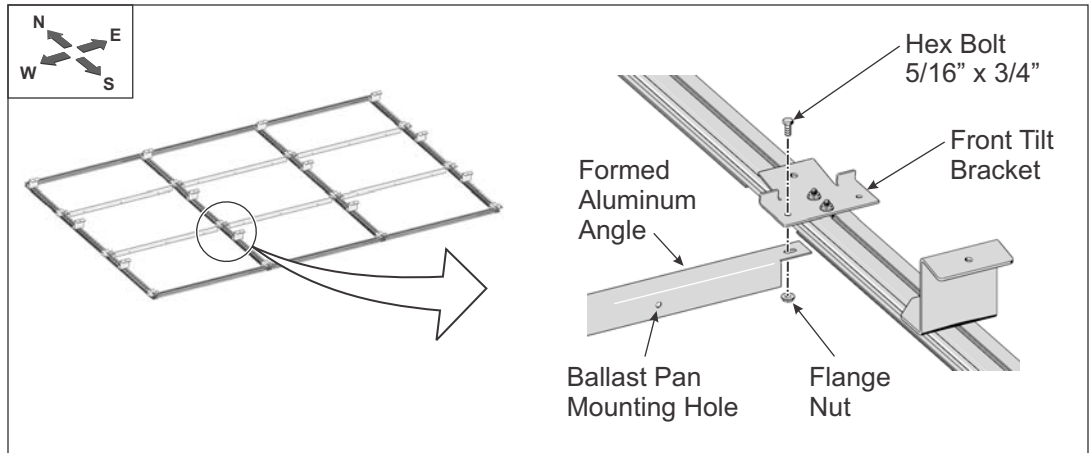

Figure 9-1: Installing the Formed Aluminum Angles

Step 10: Installing Ballast Pans

Ballast Pans are attached to the northern and southern E-W Power Beams and also the E-W Formed Aluminum Angles. Along the northern and southern E-W Power Beams, the Ballast Pans extend outward and away from the main structure. On the E-W Formed Aluminum Angles, the Ballast Pans extend to the south and are centered between the N-S Power Beams by virtue of the mounting holes of the E-W Formed Aluminum Angles.

Attaching hardware includes 5/16 x 1-3/8 inch Track Bolts and Flange Nuts for the Power Beams and 5/16 x 3/4 inch hex bolts and Flange Nuts for the E-W Formed Aluminum Angles.

Installing Ballast Pans on the E-W Power Beams.

While Ballast Pans are a standard length of 48-inches long, PV Modules vary in size. As such Ballast Pans layout and positioning is job specific. Refer to the job specific design and these instructions as needed.

Installing Ballast Pans to the E-W Power Beams:

- A. For each Ballast Pan to be installed along the length of the E-W Power Beam, install two 5/6 x 1-3/8 inch Track Bolts into the side channel of the E-W Power Beams. (See Figure 10-1)

NOTE:
Refer to job specific layout for Ballast Pan positioning.

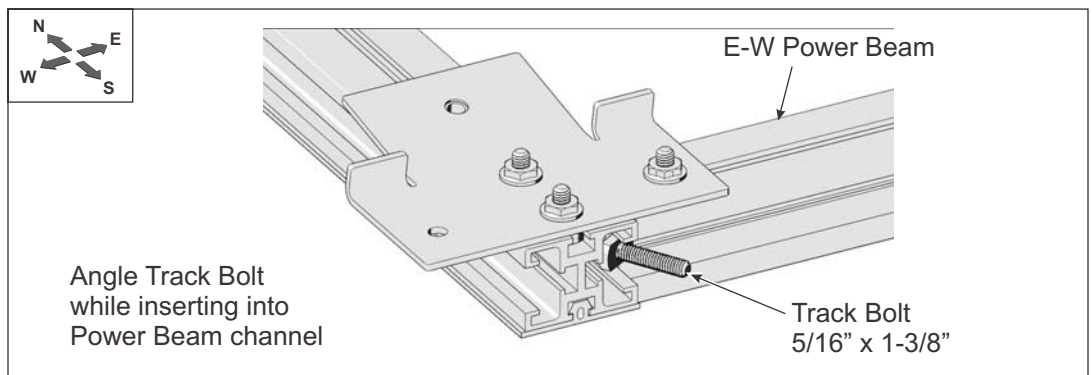

Figure 10-1: Installing Track Bolts into Power Beam

NOTE:
Track Bolts can be inserted at tee-joints where a N-S Power Beam joins the E-W Power beam.

B. Align the Ballast Pan mounting holes with the Track Bolts then install and tighten Flange Nuts. **Torque to 14-16 ft.-lbs.** (See Figures 10-2 and 10-3)

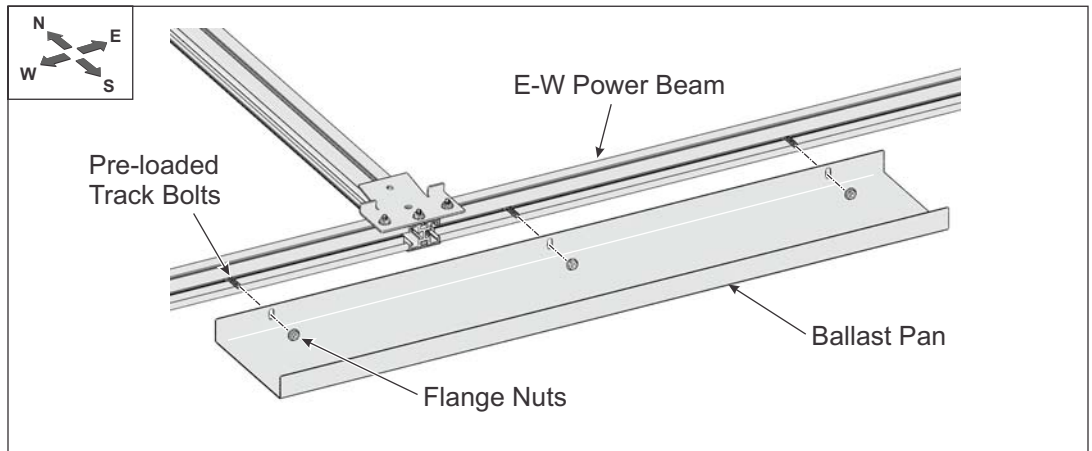

Figure 10-2: Installing a Ballast Pan to the E-W Power Beam

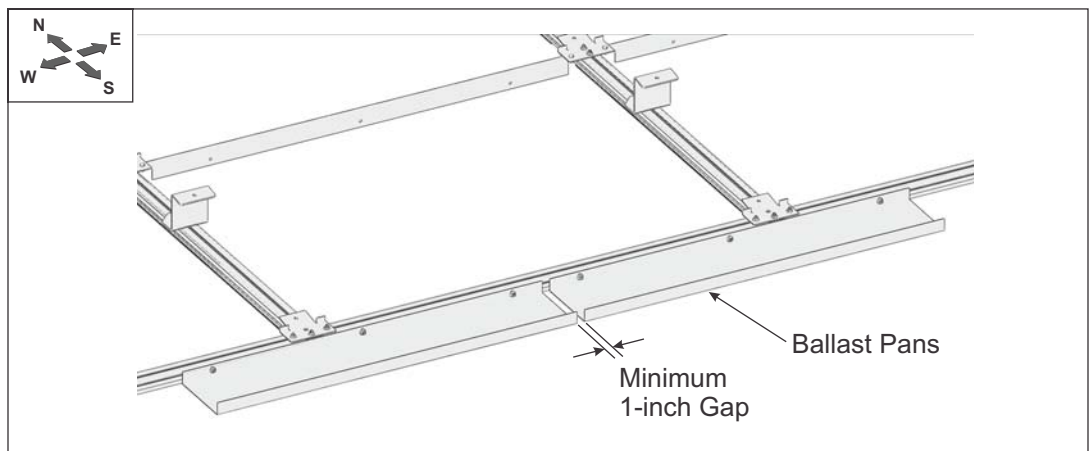

Figure 10-3: Maintain a 1-inch gap between Ballast Pans

NOTE:
Before tightening the north-most Ballast Pans to the E-W Power Beam, install the Wind Deflectors.

Repeat these steps for the remaining E-W Power Beam Ballast Pans.

The Ballast Pans along the north-most E-W Power Beam are installed similarly. However, the Wind Deflectors should be installed before the attaching hardware securing the Ballast Pans to the north-most E-W Power beam are tightened (See Step 11).

Installing Ballast Pans on the E-W Formed Aluminum Angles (See Figure 10-4):
Align the mounting holes of the Ballast Pan with the mounting holes of the E-W Formed Aluminum Angles. Insert 5/16 x 3/4 inch bolts and secure with Flange Nuts. **Torque to 14-16 ft.-lbs.**

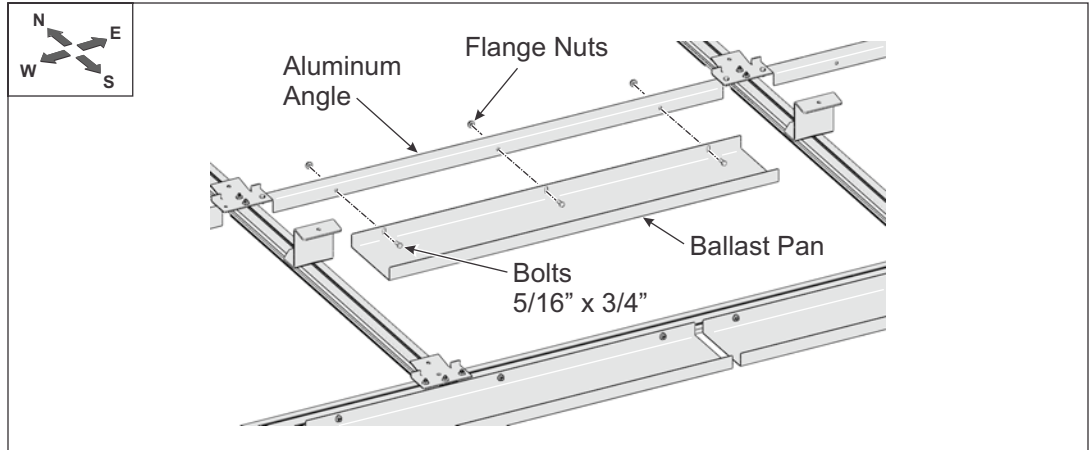

Figure 10-4: Installing Ballast Pans to the Aluminum Angles

Repeat these steps for the remaining E-W Formed Aluminum Angle Ballast Pans.

Step 11: Attaching the Wind Deflectors

Wind Deflectors are installed along the northern-most rows of the array. They utilize the same hardware as the Ballast Pans. This is achieved by aligning the Wind Deflectors notches to the attaching hardware of the Ballast Pans and sliding the Deflectors' notched edge between the Ballast Pan and the E-W Power Beam. (See Figure 11-1)

- A. Working along the northern-most E-W Power Beams with the Wind Deflector oriented so its angled flange is leaning south towards the PV Module, align the Deflectors notches to the 5/16 inch hardware and slip the Wind Deflector between the Ballast Pan and the Power Beam.
- B. Tighten all 5/16 inch attaching hardware securing the Wind Deflectors and Ballast Pans to the Power Beam. **Torque to 14-16 ft.-lbs.**

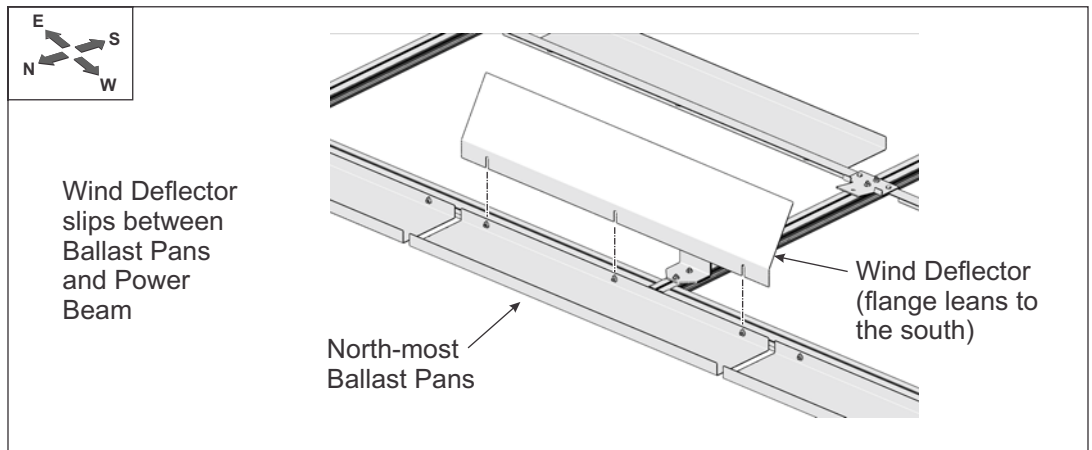

Figure 11-1: Installing Wind Deflectors

NOTE:

All ballast requirements have been calculated based on uplift and drag force data gathered from full-scale wind-tunnel testing.

CAUTION:

Be certain that the tilt angle and corresponding ballast are followed in accordance to the projects design specifications. Failure to do so could lead to catastrophic structural failure and severe personal injury or death.

* Block weight and size may vary based on site conditions. Please contact us for site-specific wind tunnel evaluation and block specification.

Step 12: Weighting Ballast Pans

Ballast Pans are lined with Concrete Cap Blocks specified at a minimum* of 2.25 H x 8 W x 16 L (dimensions are inches) weighing 14.5 Lbs. each. This requirement is designed to meet local wind speeds. Different sized cap blocks may be used as long as the weight requirements are met or exceeded.

Place the Concrete Cap Blocks side-by-side along each of the Ballast Pans. Line each of the Ballast Pans completely with the Blocks. (See Figure 12-1)

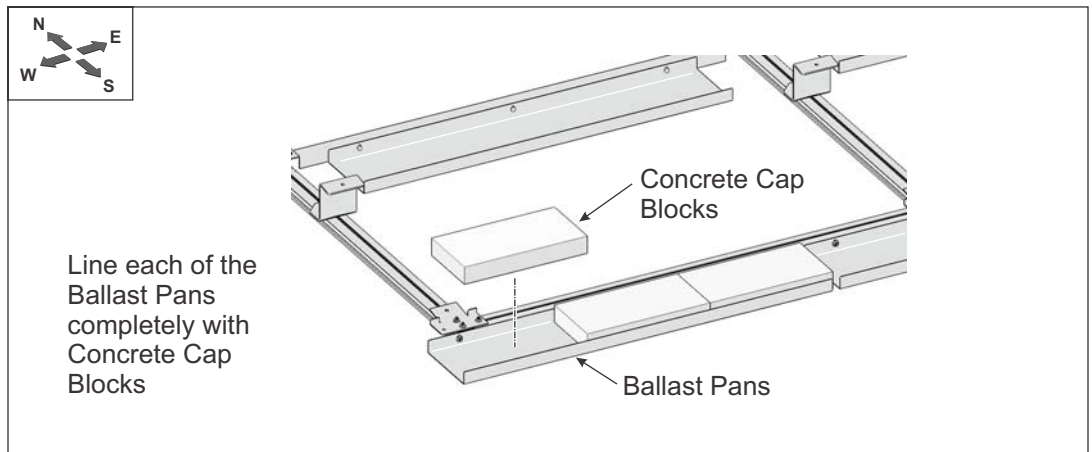

Figure 12-1: Weighting Ballast Pans with Concrete Cap Blocks

Step 13: Installing north-most PV Modules against Wind Deflectors

The north-most PV Modules must be positioned so that the Modules' north edge is butted up against the Wind Deflectors. If a gap exists between the Modules and Deflectors, an adjustment must be made to close this gap. (See Figure 13-1)

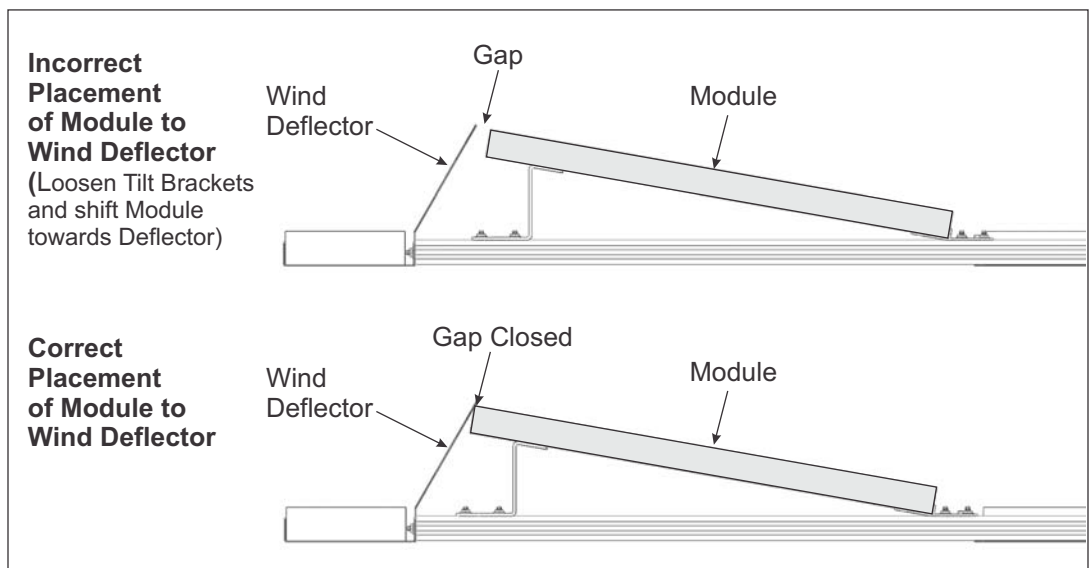

Figure 13-1: Positioning north-most Modules against Wind Deflectors

Set one north-most PV Module onto its Tilt Brackets and examine its fit against the Wind Deflectors (See Fig. 13-1 above). If a gap exists, make the following adjustments.

WARNING:

Any N-S adjustments to Tilt Brackets must be done without altering the span between the Front and Rear Tilt Brackets. This span is pre-determined by the Under Module Spacing Jig and must remain constant. If the span is altered, it could lead to damaged Modules during installation.

When adjusting Tilt Brackets in the north-south direction, adjust Front and Rear Brackets equally. This maintains the proper fit of Tilt Brackets to the Modules. (See Figure 13-2)

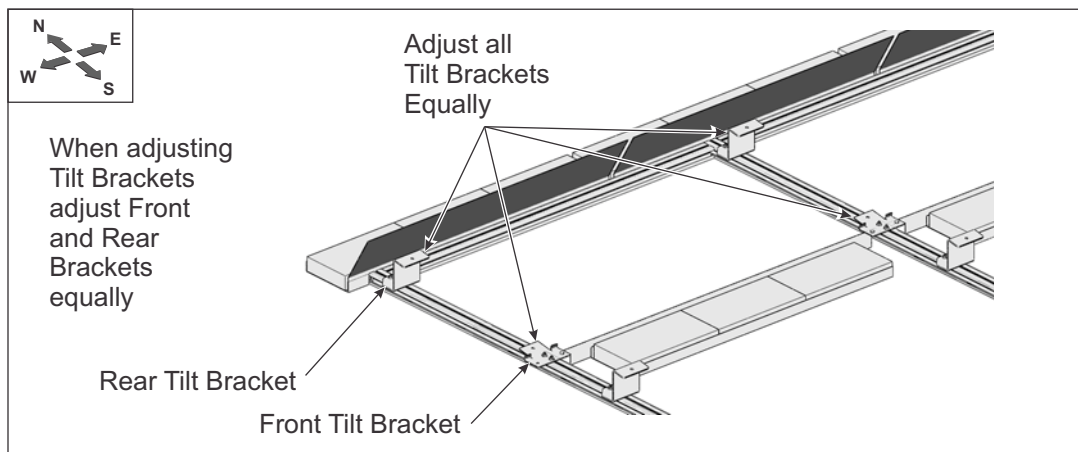

Figure 13-2: Adjusting Tilt Brackets to shift Module Position

- A. Measure the gap or overlap between the Module and Wind Deflector (See Figure 13-1).
- B. Remove the Module from the Tilt Brackets and set aside.
- C. Loosen the Flange Nuts on the Front and Rear Tilt Brackets.
- D. Using a tape measure, shift the Front and Rear Tilt Brackets in the desired direction (to close the gap or eliminate the overlap) in an amount equal to the measurement taken in step A above.
- E. Reposition the Module onto the Tilt Brackets and check the fit against the Wind Deflector. The gap or overlap should now be eliminated. If not, repeat steps A-E until the gap or overlap is eliminated.

Using the measurement taken in step A above, repeat steps B-E for each Module along the north-most run. Continue adjusting the Tilt Brackets as needed to butt the Modules against the Wind Deflectors.

Step 14: Installing PV Modules

CAUTION:

Ballast Pans must be filled with ballast before the PV Modules are installed. Failure to do so could lead to serious personal injury and/or damaged components if heavy winds develop.

WARNING:

This is a two person activity. In addition to the difficulties associated with working on a sloped rooftop, PV Modules are heavy. One person should hold and align the modules while a second person secures modules with clamping hardware. Failure to do so could lead to serious personal injury and/or damaged components.

The Modules are placed on top of the Tilt Brackets and centered with the Tilt Brackets in the E-W direction. The Modules are secured to the Tilt Brackets using Mid Clamps and End Clamps, 5/16 x XX inch bolts (length is dependent on thickness of PV Module), flat washers and lock washers.

Start in the southwest position and work outward.

- G. Position PV Module onto the southwest-most Front Tilt Brackets. Allow Module frame to rest against the tabs of the Front Tilt Brackets. Lower the rear of the Module and rest it on top of the Rear Module Tilt Brackets. (See Figure 14-1)

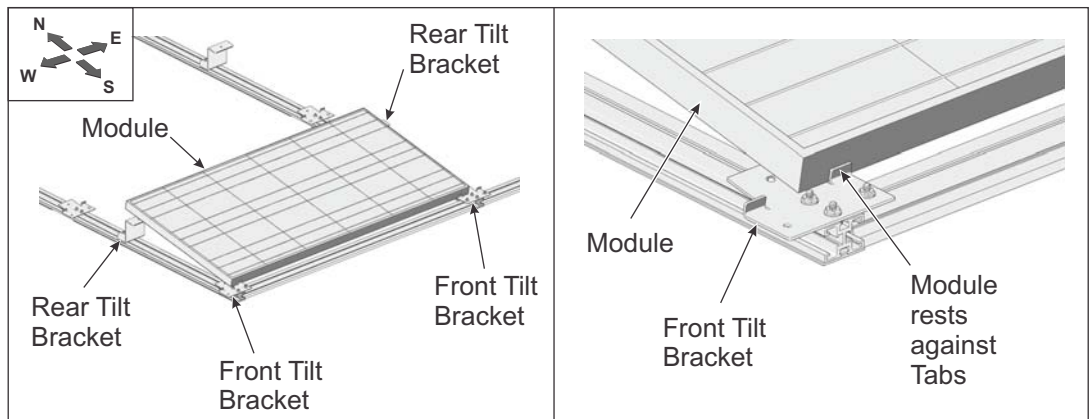

Figure 14-1: Installing PV Modules onto Tilt Brackets

- H. Using a tape measure, center the Module (from east to west) over the Tilt Brackets. Keep its frame pushed against the Front Tilt Bracket Tabs. (See Figure 14-2)

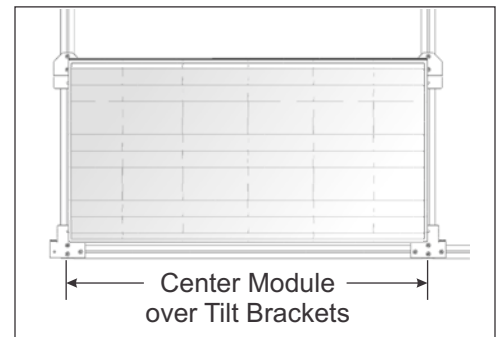

Figure 14-2: Centering the Module over the Tilt Brackets

Secure the outside edge of the Module with End Clamps. Install two End Clamps per Module one on each of the exterior Tilt Brackets (Front and Rear). (See Figure 14-3)

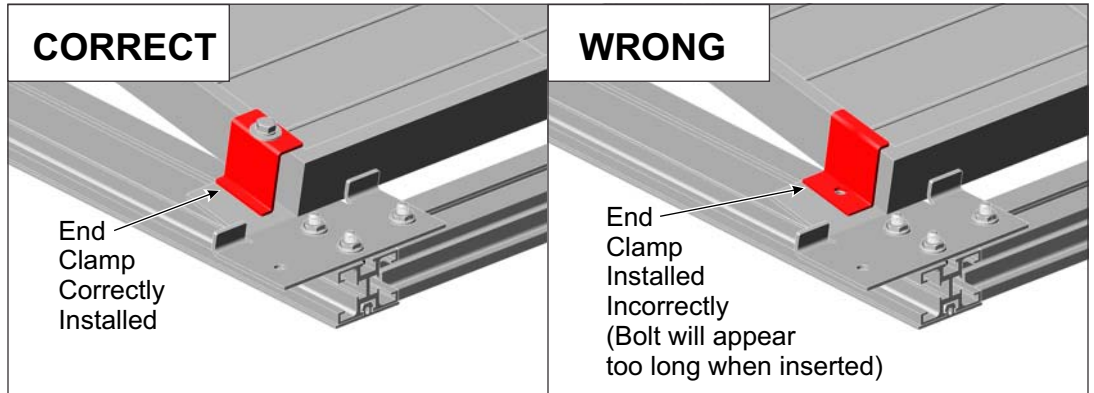

Figure 14-3: Correct and Wrong methods of installing Standard End-Clamp

- J. Insert one 5/16 x XX inch bolt (length is dependent on thickness of PV Module) along with flat and lock washers through the End Clamp and thread into the Tilt Bracket. **Torque to 14-18 ft-lbs.** (See Figures 14-4 and 14-5)

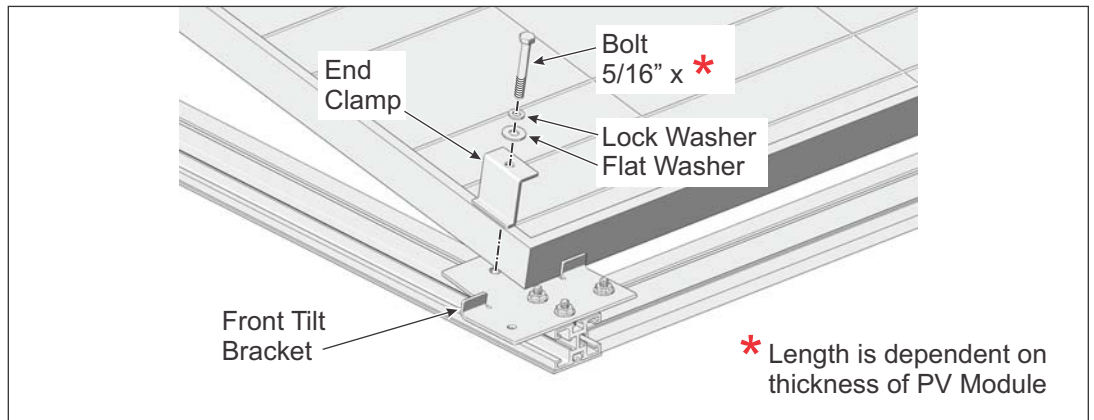

Figure 14-4: Installing an End Clamp on a Front Tilt Bracket

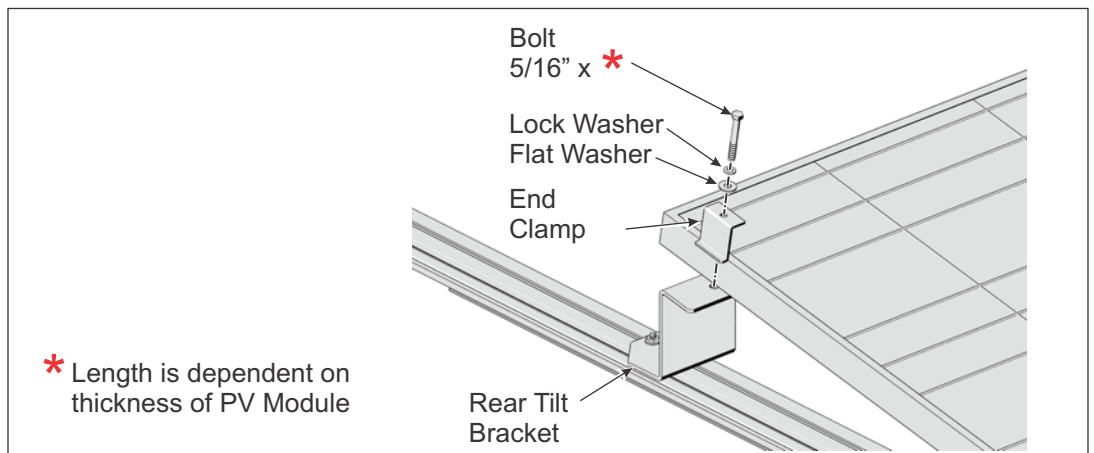

Figure 14-5: Installing an End Clamp on a Rear Tilt Bracket

Secure the inside Module edges with Mid Clamps. Install two Mid Clamps per Module, one on each of the interior Tilt Brackets (Front and Rear) between two E-W Modules. (See Figures 14-6 and 14-7)

- K. Insert one 5/16 x XX inch bolt (length is dependent on thickness of PV Module) with lock and flat washers through the Mid Clamp and thread into the Tilt Bracket. Be sure that the tabs of the Mid Clamps rest between the two Modules and the Modules are butted up against the Mid Clamp tabs. **Torque to 14-18 ft-lbs.** (See Figures 14-6 and 14-7)

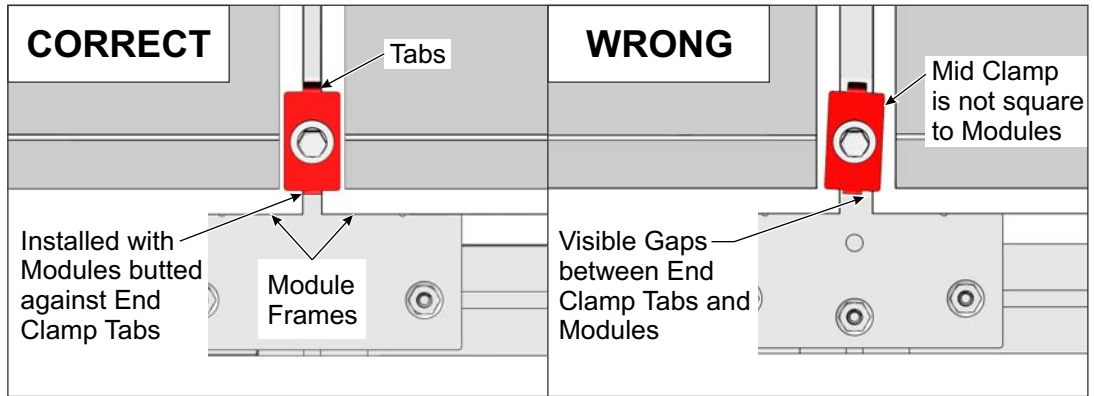

Figure 14-6: Correct and Wrong methods of installing Standard Mid Clamp

WARNING:
Be certain that all hardware has been tightened according to these specifications and torque values. Failure to do so could lead to serious personal injury and/or damaged components.

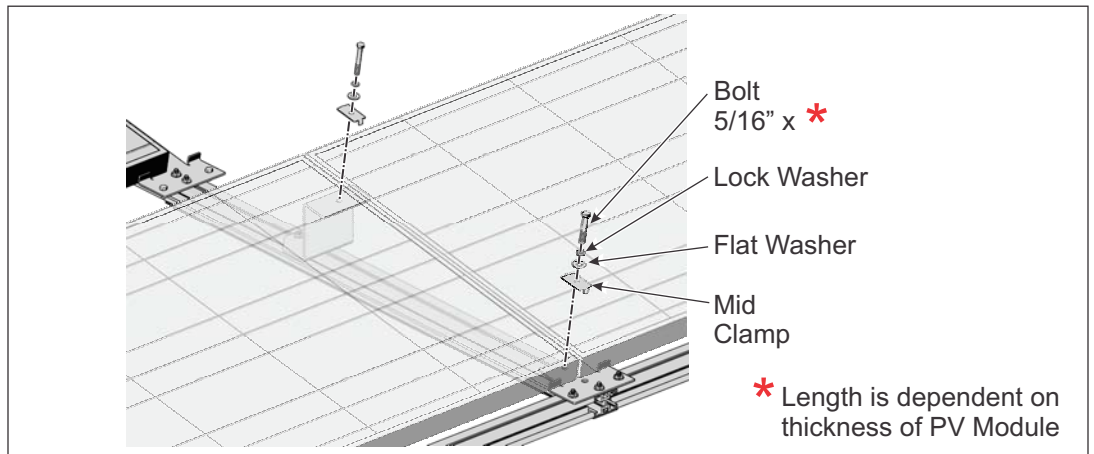

Figure 14-7: Installing Mid Clamps into Front and Rear Tilt Brackets

Repeat these steps to install remaining Modules, working from the southwest outward.



4000-B Vassar Drive NE
Albuquerque, New Mexico 87107
USA

Telephone: 800.260.3792
Fax: 505.889.3548
Web Site: www.DPWSolar.com
E-mail: info@power-fab.com

© 2011 Preformed Line Products
Part Number: 5805000, Rev H