



**DPW** | SOLAR



**PREFORMED** LINE PRODUCTS



## **POWER RAIL™ P8**

### ASSEMBLY INSTRUCTIONS

**step-by-step  
assembly and installation**

# Power Rail™ P8

## *A few words about these Assembly Instructions*

### *These instructions:*

- Do not include any information on the selection or installation of attaching hardware to be mounted to the roof substrate. For information on compatible attaching hardware see our publication titled “Power Rail Design Guidelines”.
- Begin after all roof mounted attaching hardware has been installed and secured to the roof substrate.
- Show the Power Rail Mounting System being installed on our “Power Rail PV Flash” roof attachment system.
- Are intended to be used by individuals with sufficient technical skills for the task. Knowledge and use of hand tools, measuring devices and torque values is also required.
- Include various precautions in the forms of Notes, Cautions, and Warnings. These are to assist in the assembly process and/or to draw attention to the fact that certain assembly steps may be dangerous and could cause serious personal injury and/or damage to components. Following the step-by-step procedures and these precautions should minimize the risk of any personal injury or damage to components while making the installation not only safe but an efficient process.

**WARNING:**

Follow the procedures and precautions in these instructions carefully.

For questions on a specific installation please call us or e-mail us at:

Phone: 800-260-3792

Email: [info@power-fab.com](mailto:info@power-fab.com)

### *Required Tools*

- 1/2 inch wrench or socket for 5/16 inch module clamp hardware
- Torque wrench
- Ratchet wrench
- Ratchet extension bar
- Framing square
- Tape Measure

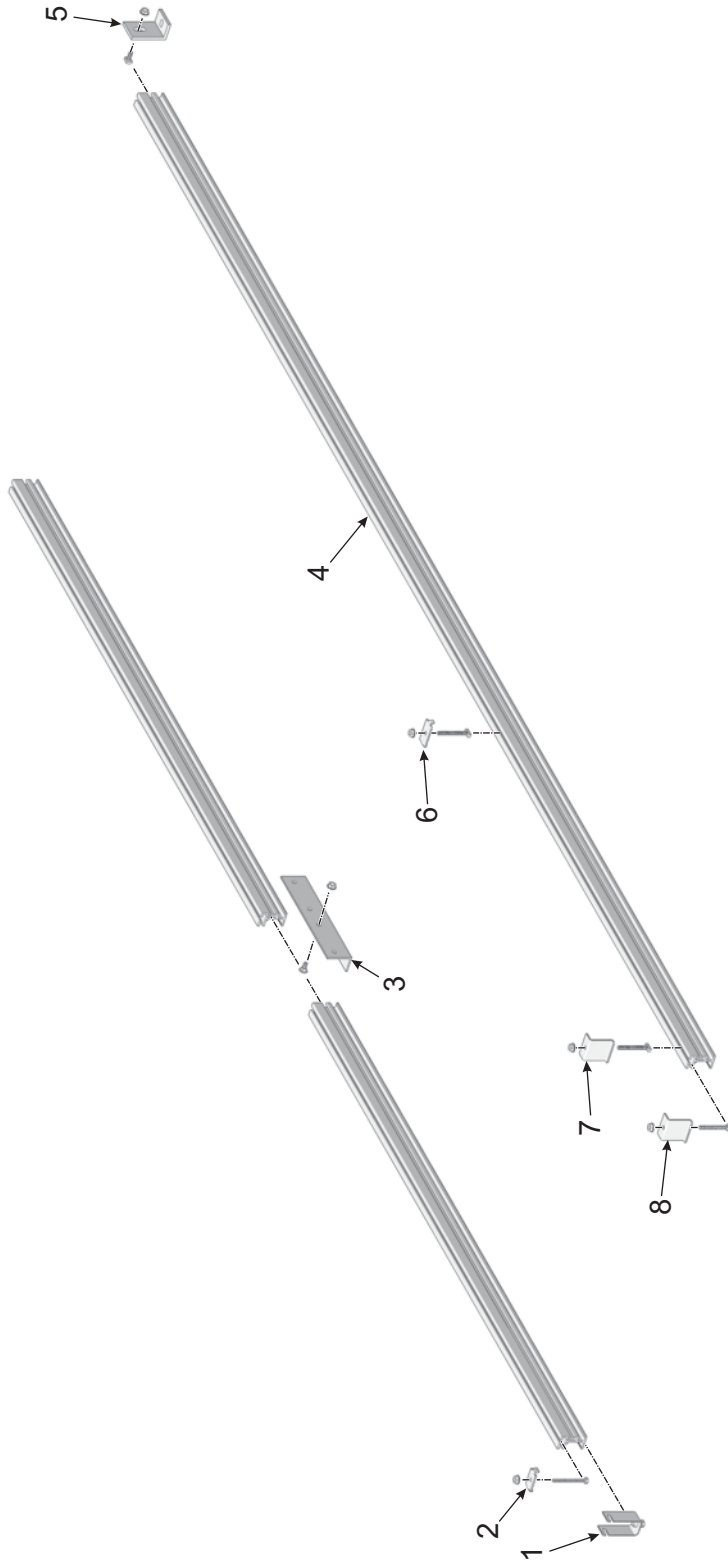

Item	Description	Qty
1	Universal End Clamp	4 per Rail Set
2	Mid Clamp, (5/16" x *) carriage bolt, flange nut	2 per 3/8" gap between modules
3	Splice Plate, set of four (5/16" x 3/4") carriage bolts, flange nuts	1 per rail joint
4	Power Rail P8	2 per Rail Set
5	L Foot, (5/16" x 3/4") carriage bolt, flange nut	Refer to Power Rail Design Guidelines
6	RAD Mid-Clamp, (5/16" x *) bolt, flange nut	2 per 3/8" gap between modules
7	RAD End-Clamp, (5/16" x *) bolt, flange nut	4 per Rail Set
8	End-Clamp, (5/16" x *) carriage bolt, flange nut	4 per Rail Set
* 2", 2-1/4", 2-1/2", or 2-3/4" bolt. Length is dependent on depth of PV Module frame		
Notes: 1. Option to install Mid Clamp with carriage bolt or RAD Mid Clamp.		
2. Option to install Universal End Clamp, End Clamp with carriage bolt or RAD End Clamp.		

**Power Rail P8 Parts Identification**

## Step 1: Securing Attaching Hardware

**NOTE:**

“L” Feet can be attached directly to the roof substrate with the proper hardware. See Power Rail Design Guidelines for more information.

The selection of attaching hardware is dependent on the roof substrate and site design conditions. Please consult the design manual for specifics. Instructions for attaching anchoring hardware to the roof or structure are available on an individual product basis.

- A. Place the “L” Foot onto the PV Flash hanger bolt, aligning it to the slot of the compression block.
- B. Secure “L” Foot with 5/16” flat washer and hex nut. **Torque to 14-16 ft.-lbs.** (See Figure 1-1)

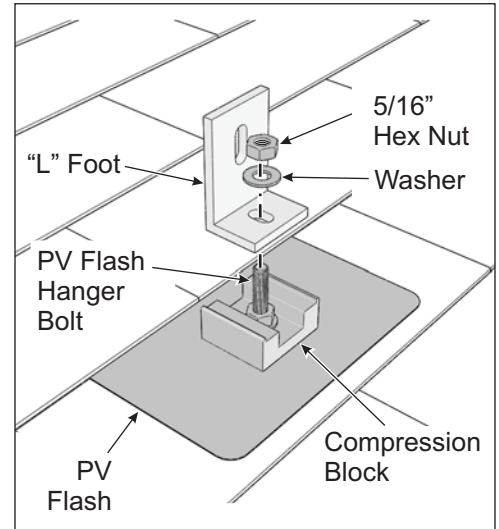

Figure 1-1: Attaching “L” Foot to the PV Flash

## Step 2: Attach Power Rail to Roof Anchors

**CAUTION:**

Cantilever and span dimensions are a design specification. Consult the design manual to match these dimensions to site conditions. It's important to use the unique cantilever and span dimension specific to the install. Failure to do so could lead to excessive deflection and/or premature system failure.

The Power Rail is secured to the “L” Feet using a 5/16” x 3/4” carriage bolt. Hardware will vary depending on design-specific requirements.

The Power Rail overhangs beyond the outermost “L” Foot. This overhang is referred to as “cantilever”, or abbreviated as "C'ver". The length of cantilever is dependent on several factors, unique to each installation and is determined by the system design. The distance between adjacent “L” Feet is referred to as "span". The length of span is dependent on several factors and unique to each installation and is determined by the system design.

- A. Measure and mark the cantilever dimension supplied by the design manual onto the Power Rail. (See Figure 2-1)

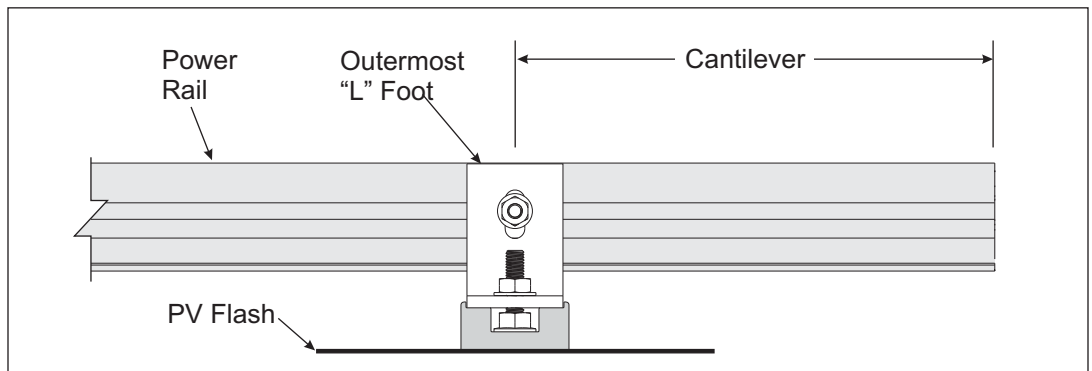

Figure 2-1: Cantilever Measurement and Marking

**NOTE:**

If using carriage bolts, be certain to slide the appropriate quantity of bolts into the Power Rail before both ends of the Power Rail have been secured.

**NOTE:**

Before tightening any flange nuts, install all bolts and flange nuts into "L" Feet along entire length of Power Rail. If tightened, the adjacent bolts cannot be passed into downstream "L" Feet.

- B. Line up the mark with the center of the outermost "L" Foot.
- C. Starting at the outermost L-foot mounting position, insert one 5/16" x 3/4" carriage bolt into the Power Rail.
- D. Holding the Power Rail, line-up and insert the 5/16" x 3/4" carriage bolt into the "L" Foot and loosely secure with 5/16" flange nut. Do not tighten until all bolts have been positioned in the entire length of the Power Rail, the bolts have been aligned and passed through the "L" Feet, and the flange nuts loosely started.
- E. Double-check that the cantilever mark is lined up with the center of the outermost "L" Foot. If needed, adjust its position to bring it into alignment.
- F. Double-check the cantilever alignment before tightening Power Rail to "L" Feet. Tighten all flange nuts and **Torque to 14-16 ft.-lbs.**

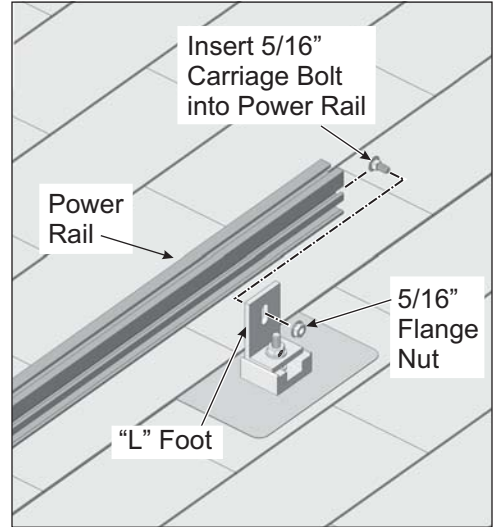

Figure 2-2: Attaching Power Rail to "L" Foot

**Step 3: Splicing Power Rail with Splice Plates**

Splice Plates are used to butt-joint Power Rail sections and extend their length as needed. They are attached to the Power Rail using four 5/16" x 3/4" carriage bolts and flange nuts.

- A. Insert two 5/16" x 3/4" carriage bolts into the end of each Power Rail section to be spliced.
- B. Hold the two ends of the Power Rail together.
- C. Position the Splice Plate onto the Power Rail and the four carriage bolts.
- D. Align the Splice Plate so that it's equally divided along the Power Rail butt-joint.
- E. Secure the Splice Plate to Power Rails with two 5/16" flange nuts. **Torque to 14-16 ft.-lbs.** (See Figure 3-1)

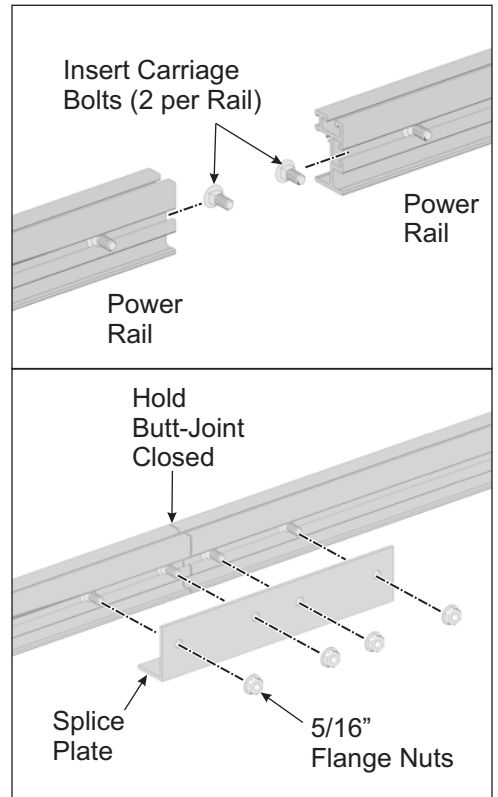

Figure 3-1: Splice Plate Installation

### Step 3: Installing PV Modules to Power Rails with Module Clamps

**WARNING:**

This is a two person activity. In addition to the difficulties related to working on a sloped rooftop, PV Modules are heavy. One person should hold and align the modules while a second person secures modules with clamping hardware. Failure to do so could lead to serious personal injury and/or damaged components.

**NOTE:**

Hardware is dependent on particular features and system design. Therefore it may appear different from these instructions.

PV Modules are secured to the Power Rail using Mid Clamps and End Clamps, both using 5/16" bolts and flange nuts.

Start with an exterior PV Module. These instructions include three options of clamping hardware. They are "Universal End Clamp" (step B1), "Standard End Clamp" (step B2), and "RAD™ Clamps" (step B3).

- A. Place exterior PV Module on two Power Rails, centering it lengthwise. Use a square to square-up Module to Power Rails.
- B1. For use with "**Universal End Clamps**": Position Universal Clamp underneath module with notches facing the outside edge of the module, and rail centered between 'forks' of the clamp. Slide clamp notches towards module flange until the flange bottoms out in the notches. Tighten 5/16" bolt on bottom of universal end clamp. **Torque to 14-16 ft.-lbs.** Repeat for both end clamps. (See Figure 3-1)

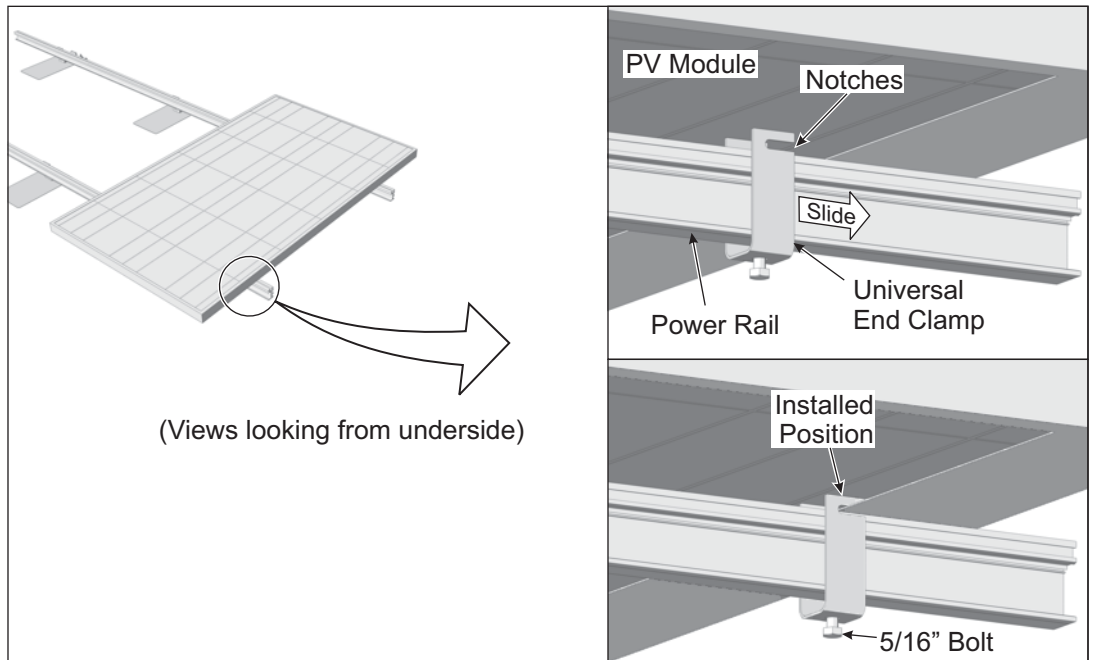

Figure 3-1: Installing PV Modules using Universal End Clamp

B2. For use with “**Standard End Clamps**”: Standard End Clamps must be installed as shown in Figure 3-2.

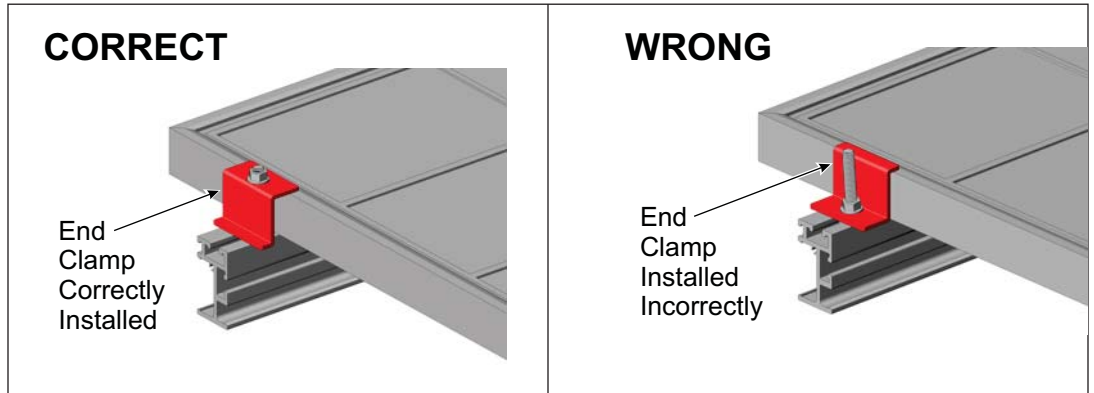

Figure 3-2: Correct and Wrong methods of installing Standard End-Clamp

Insert one 5/16” x 2, 2 1/4 or 2 1/2” carriage bolt into the top slot of the Power Rail. Push the bolt until flush with edge of module frame. Position end clamp with hole facing upwards and center hole over bolt. Seat end clamp over bolt flush with module frame. Thread 5/16” flange nut onto clamp and tighten. When desired alignment is obtained, tighten the nut and end clamp. **Torque End Clamps to 14-16 ft.-lbs.** (See Figure 3-3)

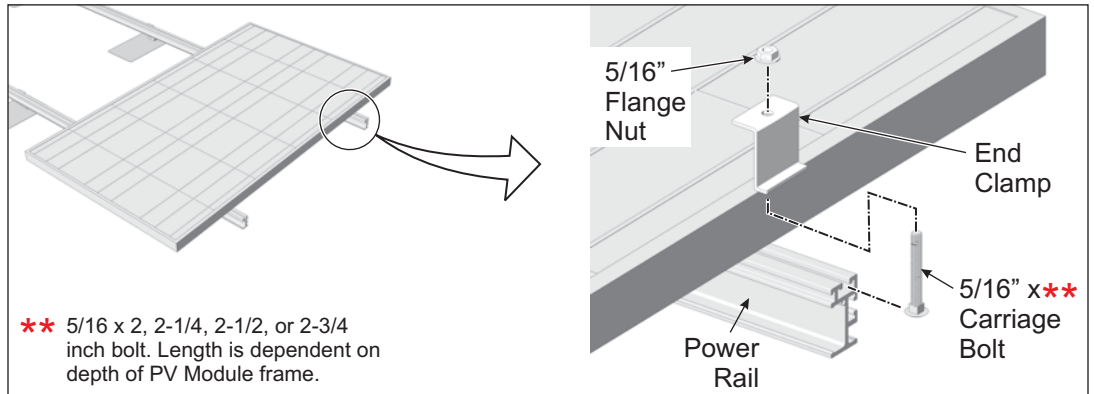

Figure 3-3: Installing PV Modules using Standard End-Clamp

B3. For use with “**RAD Hardware**”. The process is much the same as in step B2. The difference is RAD bolts can be inserted anywhere along the run of the Power Rail, not just the ends of the rail as shown in Figure 3-3 above.

Although this step demonstrates installing a *Mid-Clamp*, the procedure for an *End-Clamp* is much the same when using RAD hardware.

Insert RAD bolt into Power Rail and rotate 90-degrees to lock into rail. Install module clamp (End or Mid-Clamp) onto bolt by aligning the flat portion of the clamp with that of the bolt. Thread 5/16" flange nut onto clamp and tighten. When desired alignment is obtained, tighten the nut and end clamp. **Torque End Clamps to 14-16 ft.-lbs.** (See Figure 3-4)

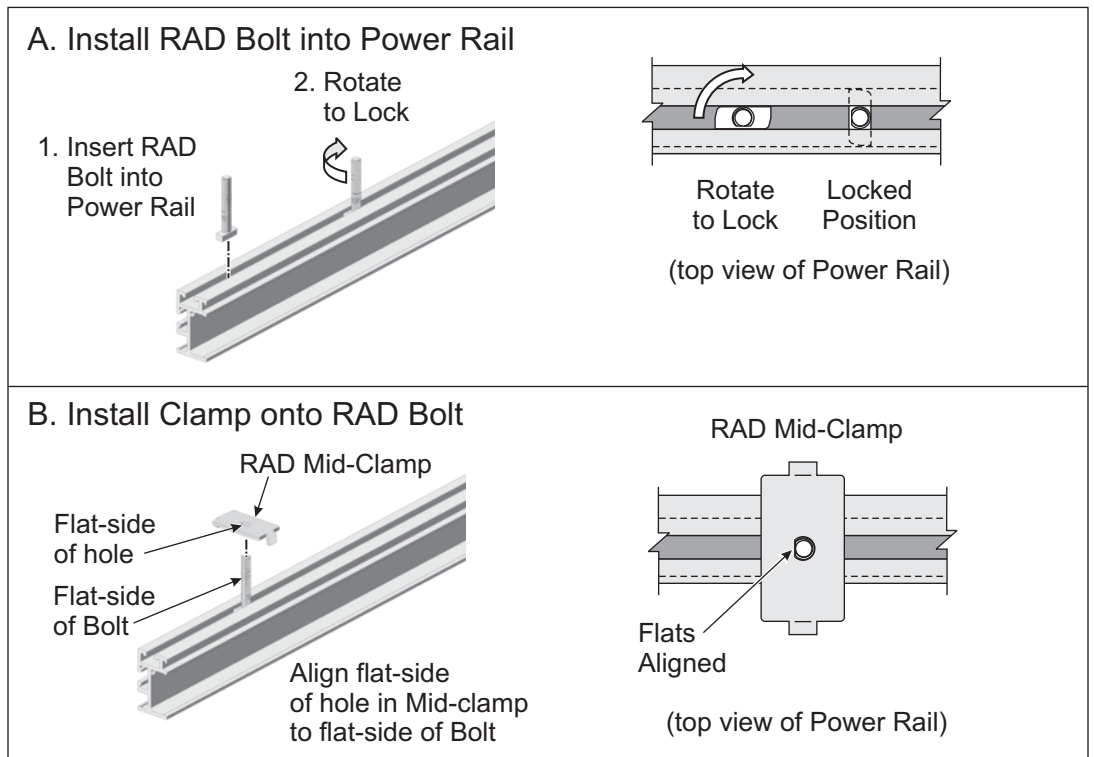

Figure 3-4: Installing PV Modules using RAD Hardware

**NOTE:**

If using standard 5/16" carriage bolts for Mid Clamps, the bolts must be inserted into Power Rail before installing interior PV Modules.

If using RAD hardware, the hardware can be inserted anytime at any position along the Power Rail.

**Installing interior Modules.**

- A. Before placing an interior Module onto the Power Rails, first insert 5/16" x 2, 2-1/4, 2-1/2, or 2-3/4 inch carriage bolts (bolt length is dependent on depth of PV Module frame) into the Module Rail, sliding the bolts inward adjacent to the previously installed exterior PV Module. (See Figure 3-5)

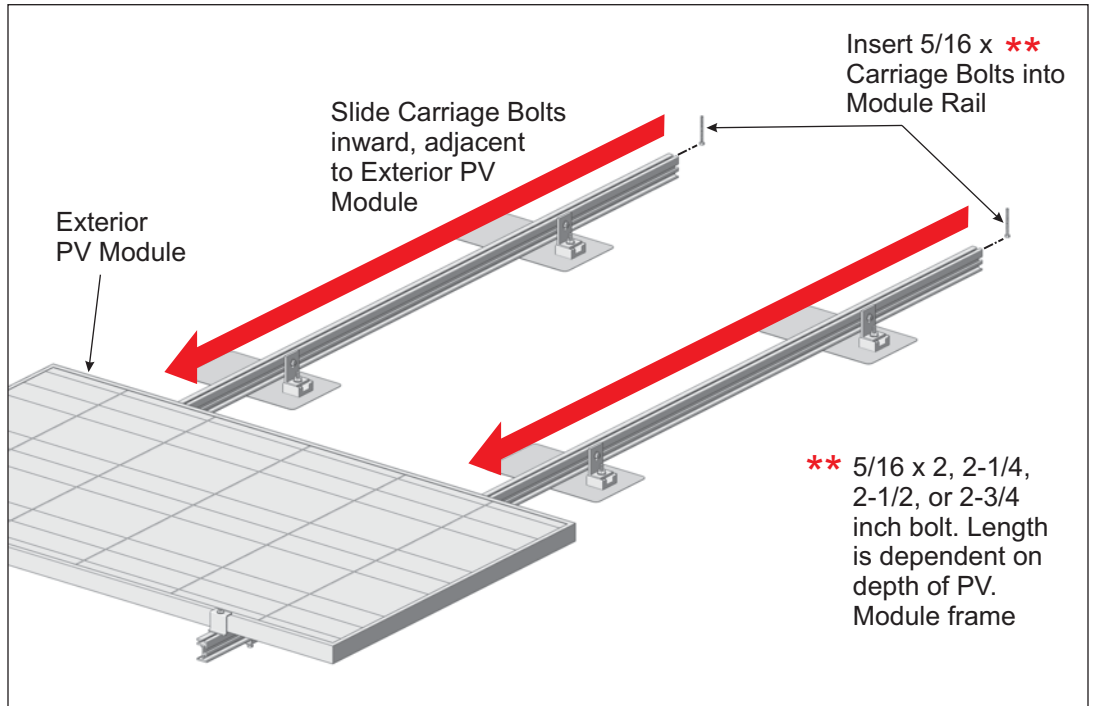

*Figure 3-5: Inserting Mid Clamp Hardware into Power Rail*

*(continued on next page)*

**WARNING:**

This is a two person activity. In addition to the difficulties related to working on a sloped rooftop, PV Modules are heavy. One person should hold and align the modules while a second person secures modules with clamping hardware. Failure to do so could lead to serious personal injury and/or damaged components.

**WARNING:**

Be certain that all Flange Nuts on End and Mid Clamps are tightened and torqued to the stated values. Failure to do so could lead to serious personal injury and/or damaged components and property.

- C. Place the interior PV Module onto the Power Rails, aligning it with the previously installed exterior PV Module. Position it adjacent to 5/16" bolts and the previously installed exterior PV Module.
- D. Use a square to square-up Module to Power Rails.
- E. Install one Mid Clamp on each of the 5/16" bolts that are between each of the interior PV Modules. Be sure that the tabs of the Mid Clamp rests between the two Modules. Secure each of the Mid Clamps with a 5/16" flange nut. **Torque Mid Clamps to 14-16 ft.-lbs.** (See Figure 3-6)

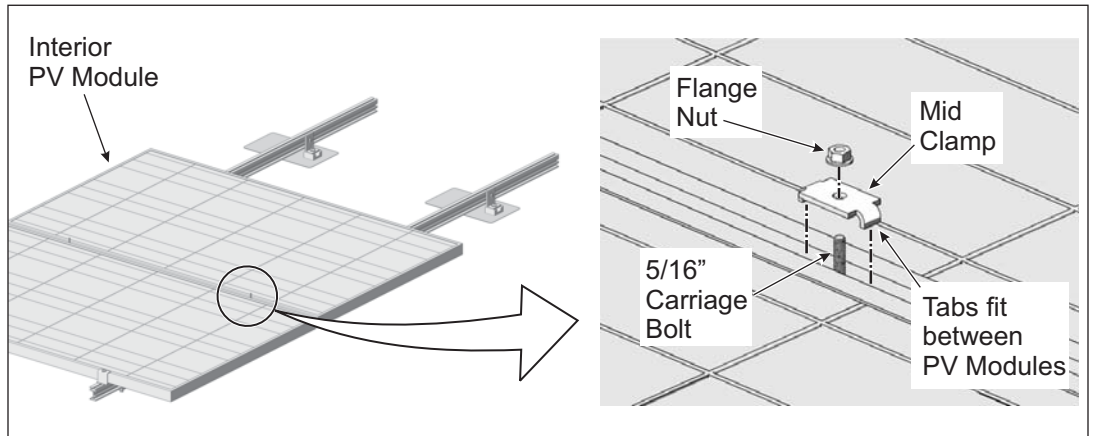

Figure 3-6: Inserting Mid Clamps



4000-B Vassar Drive NE  
Albuquerque, New Mexico 87107  
USA

Telephone: 800.260.3792  
Fax: 505.889.3548  
Web Site: [www.DPWSolar.com](http://www.DPWSolar.com)  
E-mail: [info@power-fab.com](mailto:info@power-fab.com)

© 2011 Preformed Line Products  
PCN 081711-5  
Version 1, Rev D