

PVU Power Rail™ PV Flash Installation Guidelines

Installing the PVU Power Rail PV Flash on a composition shingle roof

The PVU Power Rail PV Flash can be attached to the roof without removing any shingles. However, the rafters must be located as the PV Flash attaches to the rafters.

These guidelines begin after the rafters have been located and marked for each PV Flash to be installed. For questions about layout see *Power Rail Design Guidelines*.

Each Quik-Foot PV Flash kit includes the following items. If any items are missing, call us toll free at 800-260-3792.

Qty	Description
1	8" x 14" PV Flash
1	Aluminum Universal Attachment Block
1	Base/Mounting Plate
2	#12 x 3-1/4" Drill Point Truss Head Screws
1	3/8" x 3/4" Neoprene bonded stainless steel washer
2	3/8"-18 Stainless steel hex nuts
1	3/8" x 11/16" Stainless steel flat washer

Step 1: Position Base Plate and Drill Pilot Holes

- A. Position the Base Plate by centering over rafter as shown in Figure 1-1. Mark the two locations where pilot holes will be drilled.
- B. Remove the Base Plate and drill two 1/8" pilot holes into the rafter.

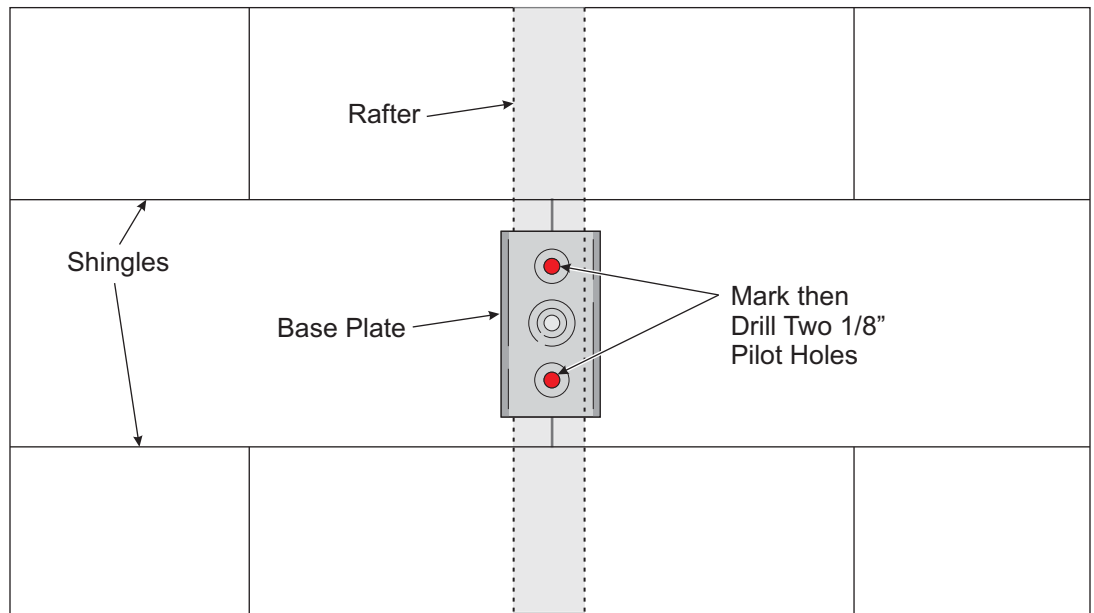

Figure 1-1: Positioning the Base Plate and Drilling Pilot Holes

Step 2: Installing Base Plate

- A. Align the Base Plate over the previously drilled pilot holes and secure with two #12 x 3-1/4" Truss Head screws driving them into the rafter. (See Figure 2-1)

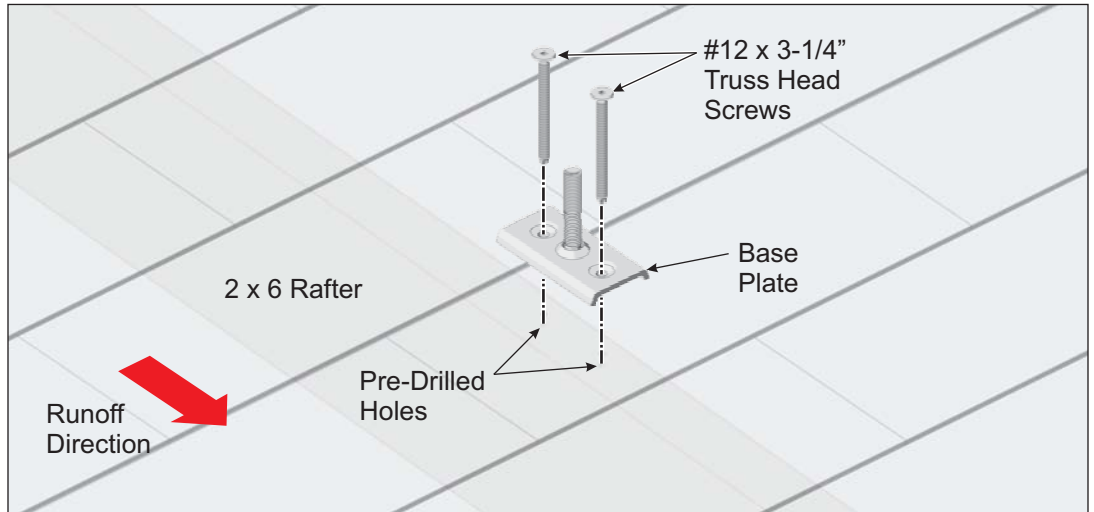

Figure 2-1: Installing Base Plate

Step 3: Install PV Flash on Base Plate

- A. While lifting the upper row of shingles, align the mounting hole of the PV Flash with the Base Plate stud and slide the upper portion of the flash under the upper row of shingles.
- B. Align the PV Flash and press down onto the Base Plate. (See Figure 3-1)

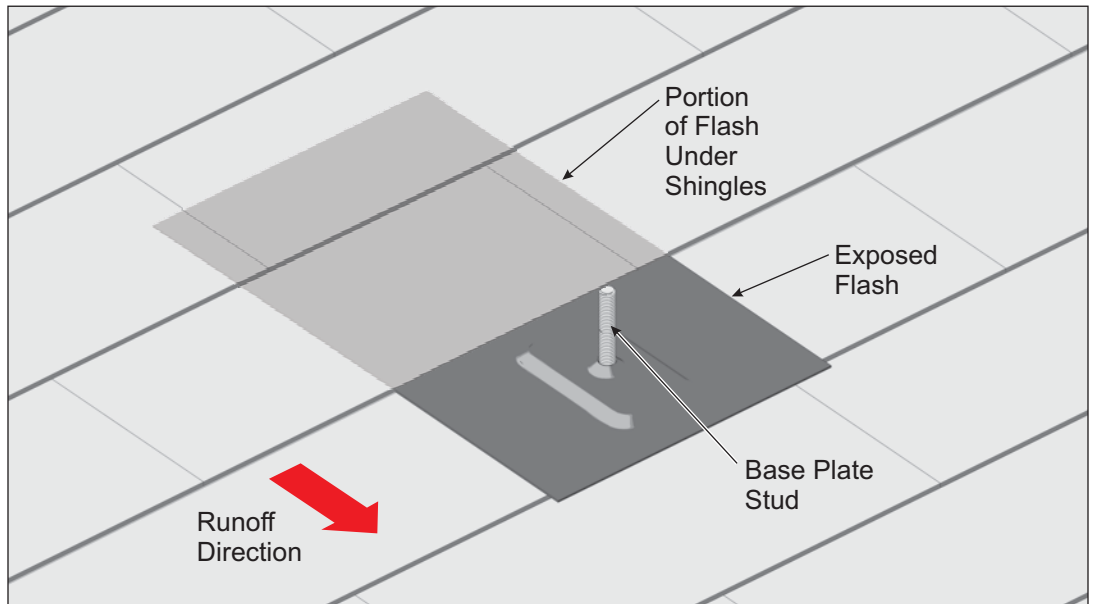

Figure 3-1: Installing PV Flash to Base Plate

Step 4: Install Universal Attachment Block and Plate

- A. Place the Universal Attachment Block onto exposed stud of the Base Plate.
- B. Install the EPDM-Bonded washer followed by one of the 3/8" hex nuts. Tighten nut to secure the Universal Attachment Block and PV Flash to the Base Plate. (See Figure 4-1)

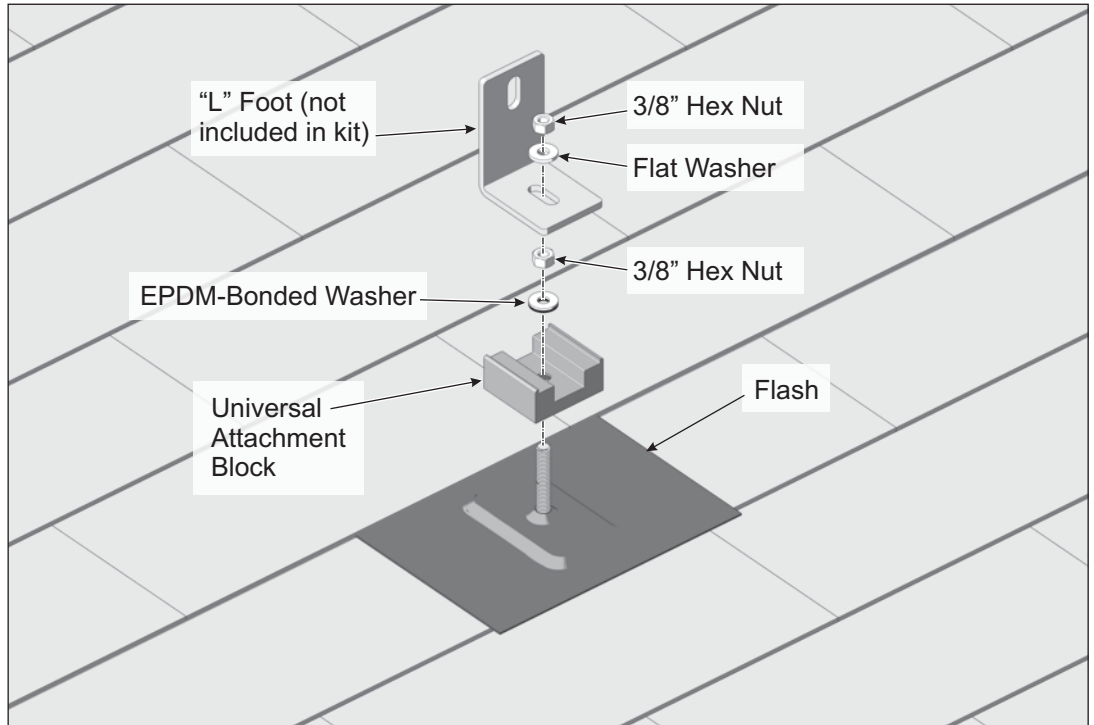

Figure 4-1: Installing Universal Attachment Block



4000-B Vassar Drive NE
Albuquerque, New Mexico 87107
USA

Telephone: 800.260.3792
Fax: 505.889.3548
Web Site: www.DPWSolar.com
E-mail: info@power-fab.com

© 2011 Preformed Line Products
PCN 061611-1
Version 1, Rev C