



DPW | SOLAR



PREFORMED LINE PRODUCTS



MULTI-POLE MOUNT - G2

Assembly Instructions

**step-by-step
assembly and installation**

The Multi-Pole Mount - G2

A few words about the product

The Multi-Pole Mount - G2 (MPM-G2) is designed to mount on 3, 4, or 6 inch SCH40/80 vertical steel pipe (installer supplied), and 4 x 4 inch square, or 5 x 4 inch rectangular horizontal tube. The goal of the MPM design is to limit the number of ground penetrations which helps reduce ground work and the associated labor costs.

Pipe size and foundation requirements are based on several factors including the array surface area, maximum design wind speed, exposure category, soil type, tilt angle and above-ground clearance.

For foundation and pipe size recommendations on a specific installation please contact us at:

Phone: 800-260-3792

Email: info@power-fab.com.

WARNING

STAINLESS STEEL HARDWARE CAN GALL WHEN TIGHTENED TOO QUICKLY. INSTALLER SHOULD USE A SILVER GRADE ANTI-SEIZE COMPOUND PRIOR TO ASSEMBLING ANY STAINLESS STEEL HARDWARE. DO NOT USE AN IMPACT DRIVER. ALL OTHER DRIVER TYPES SHOULD BE SET TO LOW SPEED SETTINGS.

WARNING:
Follow the procedures and precautions in these instructions carefully.

Assembly Instructions

These instructions include information on assembling the product and are intended to be used by individuals with sufficient technical skills for the task. Knowledge and use of hand tools, measuring devices and torque values is also required.

Included in these instructions are various Notes, Cautions, and Warnings that are intended to draw your attention and assist in the assembly process and/or to draw attention to the fact that certain assembly steps may be dangerous and could cause serious physical injury and/or damage to components. Follow the procedures and precautions in these instructions carefully.

Required Tools

- 1/2 inch wrench or socket for 5/16 inch module clamp hardware
- 3/4 inch wrench or socket for 1/2 inch hardware
- Torque wrench
- Ratchet wrench
- Ratchet extension bar
- 3 to 6 foot level
- Framing square
- Tape Measure

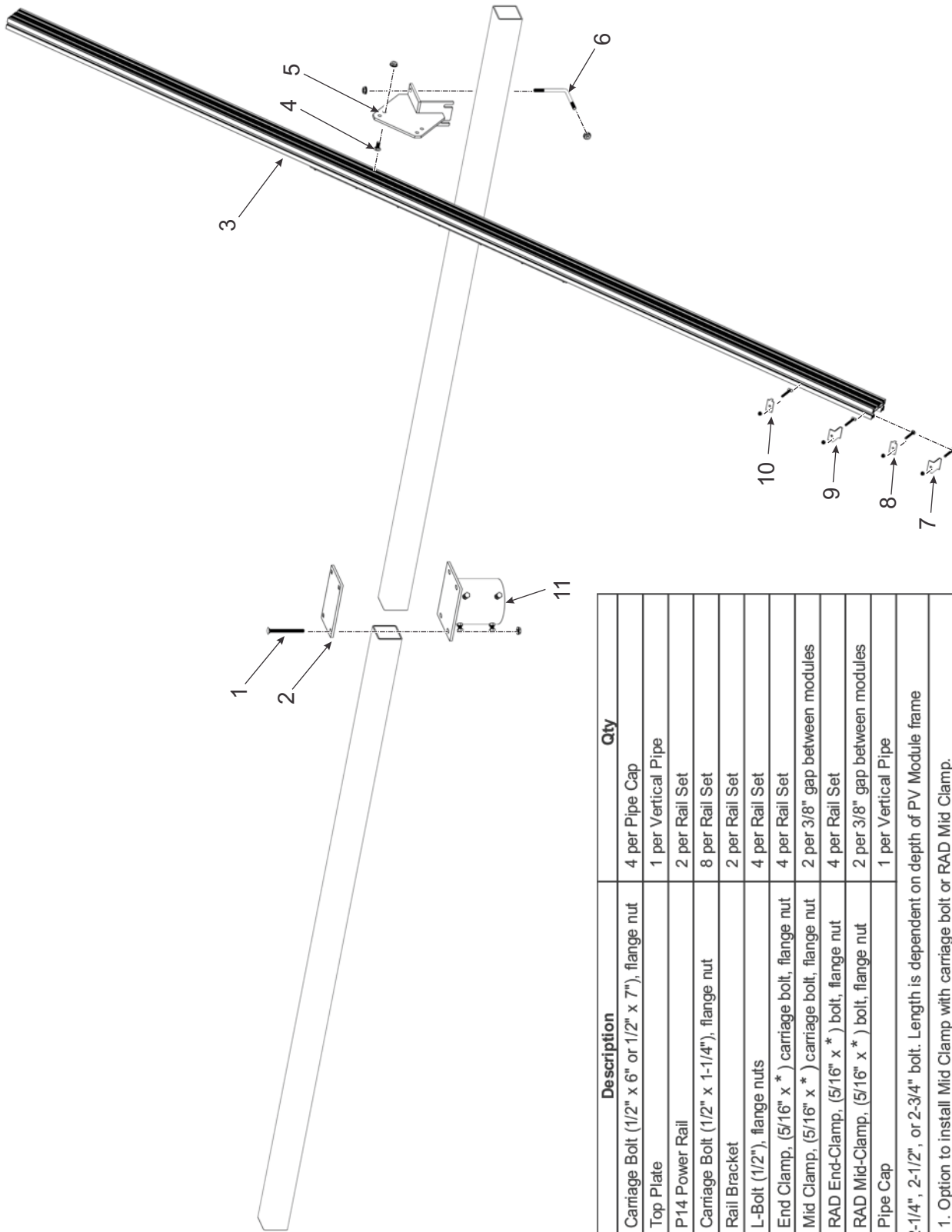

Item	Description	Qty
1	Carrage Bolt (1/2" x 6" or 1/2" x 7"), flange nut	4 per Pipe Cap
2	Top Plate	1 per Vertical Pipe
3	P14 Power Rail	2 per Rail Set
4	Carrage Bolt (1/2" x 1-1/4"), flange nut	8 per Rail Set
5	Rail Bracket	2 per Rail Set
6	L-Bolt (1/2"), flange nuts	4 per Rail Set
7	End Clamp, (5/16" x *) carriage bolt, flange nut	4 per Rail Set
8	Mid Clamp, (5/16" x *) carriage bolt, flange nut	2 per 3/8" gap between modules
9	RAD End-Clamp, (5/16" x *) bolt, flange nut	4 per Rail Set
10	RAD Mid-Clamp, (5/16" x *) bolt, flange nut	2 per 3/8" gap between modules
11	Pipe Cap	1 per Vertical Pipe

* 2", 2-1/4", 2-1/2", or 2-3/4" bolt. Length is dependent on depth of PV Module frame

Notes: 1. Option to install Mid Clamp with carriage bolt or RAD Mid Clamp.
 2. Option to install Universal End Clamp, End Clamp with carriage bolt or RAD End Clamp.

Multi-Pole Mount - G2 Parts Identification

Step 1: Install Pipe Cap on Vertical Pipes

Before installing Pipe Caps, verify that all Vertical Pipes are level to one another.

Install one Pipe Cap on each Vertical Pipe. The Pipe Caps have three or four set bolts each to secure the Pipe Caps to the Vertical Pipe. (See Figure 1-1)

- A. Slip the Pipe Cap on top of the Vertical Pipe and slide it down until it rests/bottoms out on top of the Vertical Pipe.
- B. Rotate the Pipe Cap so that the long dimension of the flange is aligned with the direction of the Horizontal Square Tube (to be installed in Step 2).
- C. For now, finger-tighten the three or four set bolts so that the Pipe Cap is free to rotate as needed for Step 2.

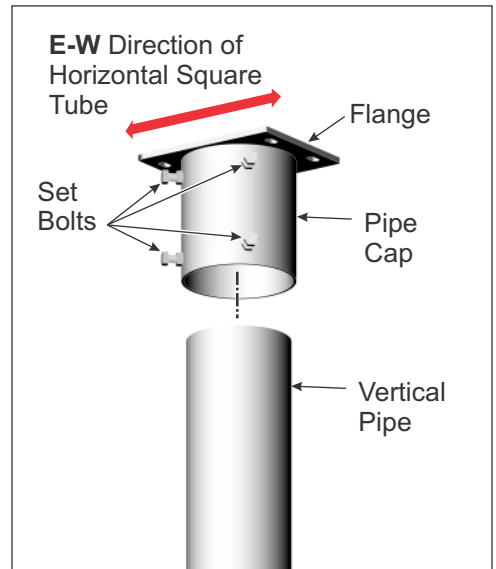

Figure 1-1: Installing Pipe Cap

Step 2: Install the Horizontal Tube

The Horizontal tubes are secured to the Pipe Caps using a Top Plate along with four carriage bolts and flange nuts. The Tubes have been cut to length to match the spans of the previously installed vertical pipes. The ends of the Tubes are butted to each other on top of each Pipe Cap. (See Figure 2-1)

- A. Lift and position the Horizontal Tubes onto the Pipe Caps, creating a butt joint centered (± 1 ") over the Pipe Cap.
- B. Install the Top Plate, securing it to the Pipe Cap with four 1/2" x 6" or 7" Carriage Bolts and Flange Nuts. **Torque to 60-70 ft.-lbs.**
- C. Tighten the three or four set bolts on each Pipe Cap. **Torque to 32-34 ft.-lbs. for 3/8" hardware or 55-60 ft.-lbs. for 1/2" hardware.**
- D. Repeat for all remaining Pipe Caps.

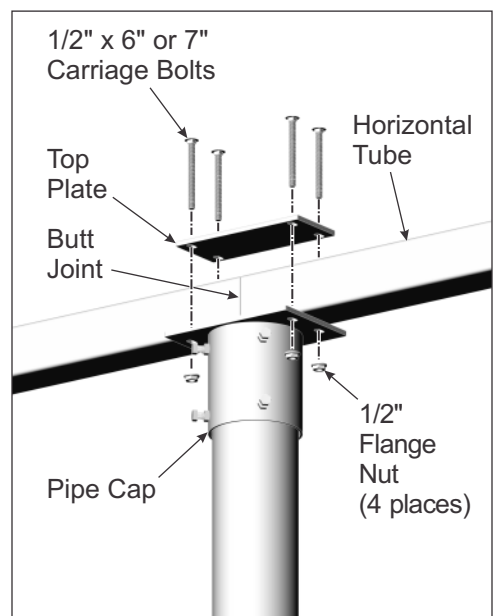

Figure 2-1: Installing Horizontal Pipe

CAUTION:

Before assembly, be certain that the vertical pipe installation has met the project requirements and the concrete footings have fully cured.

NOTE:

For foundation and pipe recommendations, fill out the MPM RFQ form and email to: info@power-fab.com

WARNING:

This is a two person activity. The Horizontal Square Pipes are heavy and unstable before secured. One person should hold the pipe while the other secures it to the Mounting Sleeves. Failure to do so could lead to serious personal injury.

Step 3: Assemble the Rail Set Assemblies

CAUTION:

Use care while working around the structure during assembly. There could be components that create hazards or obstruct free movement causing serious bodily injury. Many are at head/eye level. Move slowly and with care around the work area.

The Rail Set Assemblies include one section of Power Rail secured to one Rail Bracket. The Power Rail is secured to the Rail Bracket using 1/2" x 1-1/4" carriage bolts and flange nuts.

Be certain to orient the Power Rail to the Rail Bracket as shown in Figure 3-1.

- A. Along its length, measure and mark the center of the Power Rail.
- B. Insert four 1/2" x 1-1/4" carriage bolts into the Power Rail channel. Slide them towards the center mark of the rail. (See Figure 3-2)
- C. Mount the Rail Bracket onto the two carriage bolts aligning the center of the Rail Bracket to the center mark on the Power Rail. Secure with flange nuts. **Torque to 60-70 ft-lbs.**

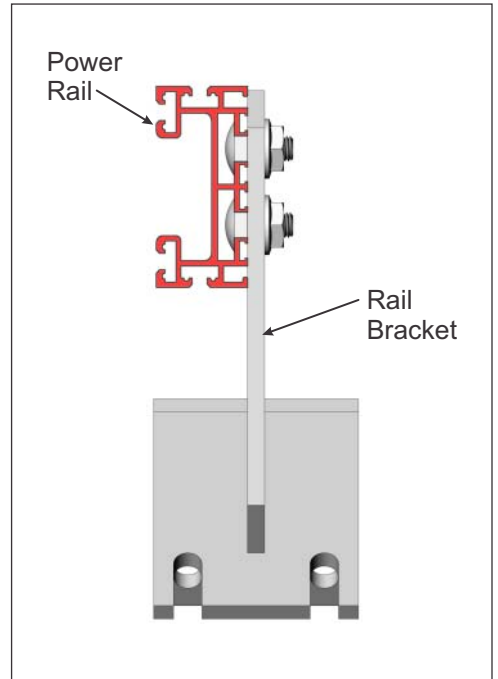

Figure 3-1: Orientation of Power Rail to Rail Bracket

NOTE:

Be sure that the Rail Bracket is properly oriented to the Power Rail.

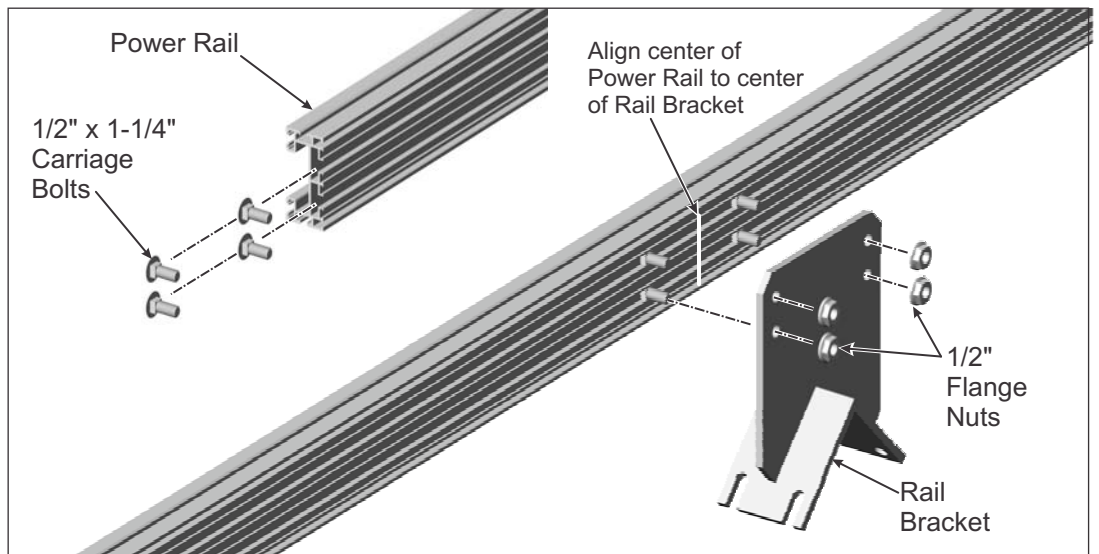

Figure 3-2 Assembly of the Rail Set Assemblies

Step 4: Attaching the Rail Set Assemblies to the Horizontal Tube

Each Rail Set Assembly is secured to the Horizontal Tube using two 1/2" L-Bolts and four Flange Nuts per Rail Set.

Rail Set Assemblies are spaced along the Horizontal Tube in predetermined spans. The span between each is dependent on the size of Modules to be used. Follow the instructions below to measure and mark the locations of the Rail Set Assemblies on the Horizontal Tube. If a Rail Set Assembly lands on or near a Pipe Cap and prevents the Pipe Cap from being properly secured to the Horizontal Tube, the Assembly must be shifted to work around the Pipe Cap. This procedure is also explained below.

It is best to start from the center of the Multi-Pole Mount-G2 system and work outward. This will ensure a centered array over the system.

- A. Start by measuring and marking the center of the entire run of Horizontal Tube.
- B. Determine if there are an odd or even number of modules per row. Refer to the title block of the Layout Drawings for this number. (See Figure 4-1)

Total Modules	Sets of Modules	Number of Rows
 DIRECT POWER AND WATER 4000 VASSAR DRIVE NE ALBUQUERQUE, NEW MEXICO 87107		
TITLE: DP-MPM124-YNG230-31x4		
CUSTOMER:	PRO-TECH ENERGY	DRAWN BY: A.G. DATE: 7-29-10
PROJECT:	PEDDIE SCHOOL SUB ARRAY 9	ENGINEER: J.R. SHT. 2
<small>THIS DRAWING IS THE PROPERTY OF DPW SOLAR, AND CANNOT BE USED, COPIED, OR DISCLOSED WITHOUT PERMISSION. DO NOT SCALE DRAWING</small>		

In this example there are:
31 Sets of 4 Modules in Landscape

Figure 4-1: Sample Title Block from DPW Layout Drawing - Use to determine number of Modules Per Row

- C. Measure and mark the locations of the Rail Sets along the Horizontal Tube as shown in the either Figure 4-2 for odd numbers or Figure 4-3 for even numbers of modules.

As a rule-of-thumb, Rail Sets are centered under each Module with a span between Rail Set Assemblies equal to 60% of the Module length. Once these are measured and marked, the next-in-line Rail Set Assembly is measured and marked using a factor equal to 20% of the Module Length plus 1/2" (the 1/2" is the spacing between Modules). Calculate the 20% factor, double it and add 1/2" the end result is the span (center to center) for the next-in-line Rail Set Assembly.

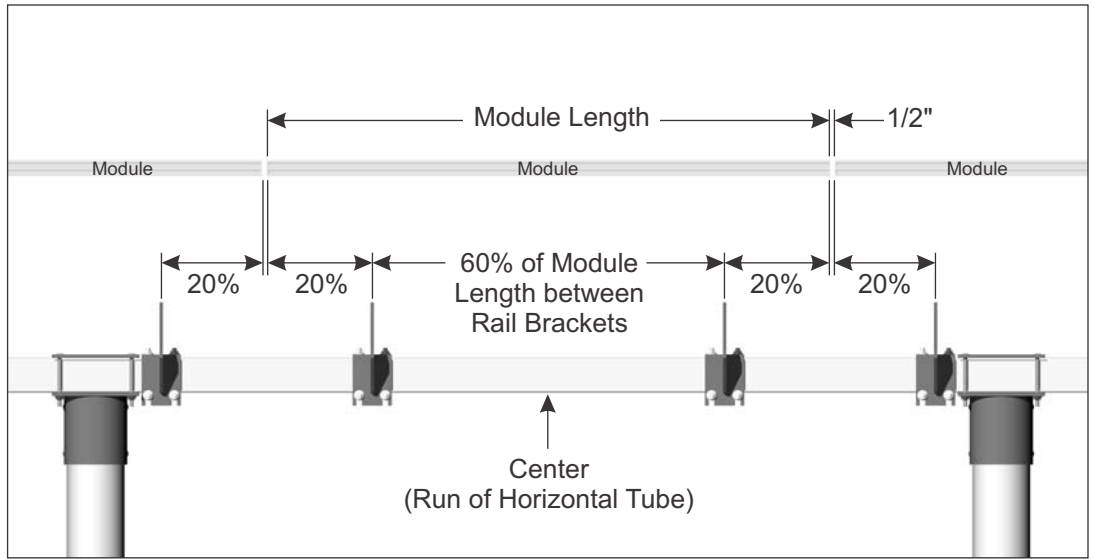

*Figure 4-2: Establishing Position and Spacing of Rail Set Assemblies - for an install with an **Odd number of Rail Sets***

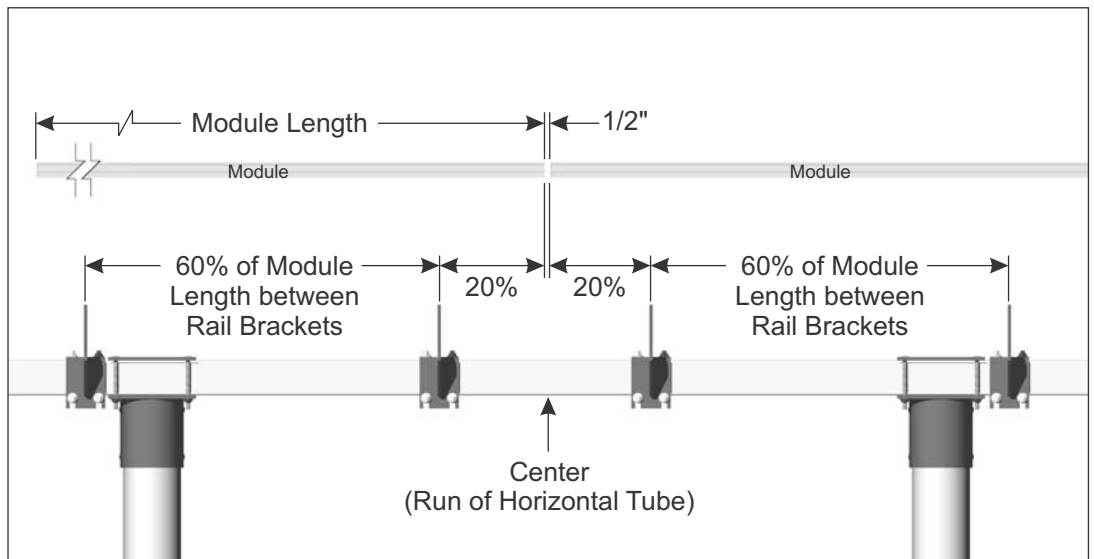

*Figure 4-3: Establishing Position and Spacing of Rail Set Assemblies - for an install with an **Even number of Rail Sets***

How to work around the Pipe Caps

There will likely be situations where the placement of the Rail Set Assembly (using the guidelines above) is such that the assembly lands too close or on top of a Pipe Cap/Top Plate in such a manner as to prevent the assembly from being properly installed. If this occurs, the Rail Set Assembly must be repositioned in order to avoid the Pipe Cap and allow proper attachment of the assembly to the Horizontal Pipe. If repositioning is required, it must be done in such a way that the Rail Set Assembly is repositioned as close as is possible to the Pipe Cap while still allowing for proper attachment to the Horizontal Tube. (See Figure 4-4)

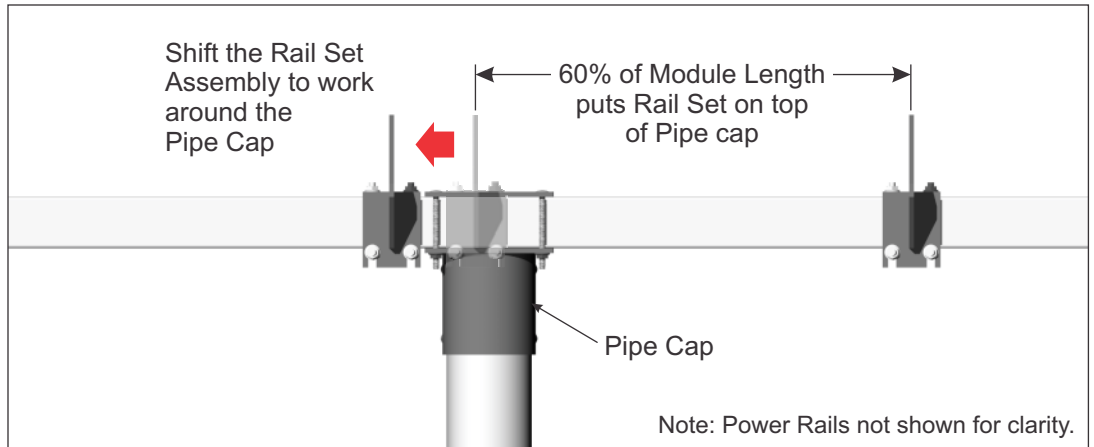

Figure 4-4: Repositioning a Rail Set to work around a Pipe Cap

Attaching the Rail Sets to the Horizontal Tube

WARNING:

This is a two person activity, because the Rail Set is unstable before it's secured. One person should steady the Rail Set while the other secures it. Failure to do so could lead to serious personal injury.

CAUTION:

Be sure to tighten the L-Bolts evenly to close any gaps and keep the Rail Bracket tight against the Horizontal Pipe.

- A. Using a tape measure, mark the pre-determined locations of the Rail Sets on the Horizontal Tube using the instructions outlined above. (See Figure 4-5)
- B. Place the Rail Set on top of the Horizontal Tube, aligning it to its mark made in Step A above.
- C. From below, insert the two 1/2" L-Bolts into the two holes of the Rail Bracket guiding the opposite ends into the two notches on the opposite side of the Rail Bracket. Loosely thread two 1/2" Flange Nuts on each of the L-Bolts.
- D. Continue to tighten the Flange Nuts, alternating between the four so the L-Bolts and Rail Bracket are drawn evenly against the Horizontal Pipe. (See Figure 4-6) **Torque all four to 60-70 ft.-lbs.**

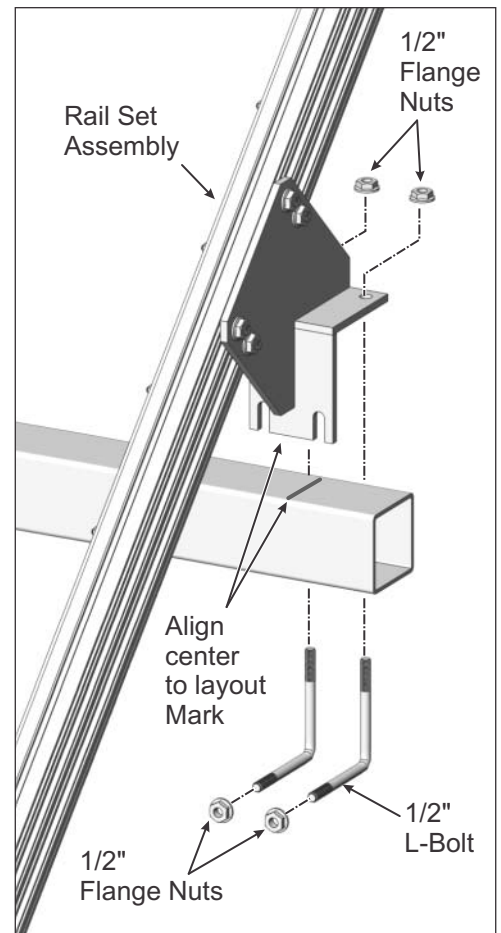

Figure 4-5: Attaching the Rail Set to the Horizontal Tube

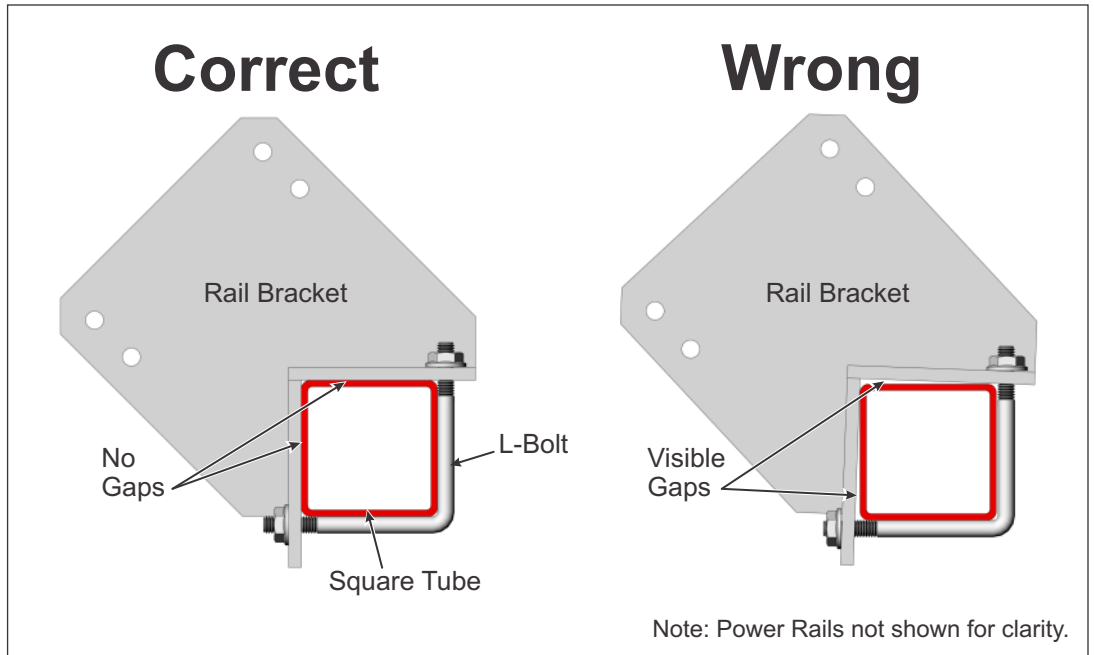

Figure 4-6: Alternate Tightening of L-Bolts to Close Gaps

Step 7: Attaching Modules to the Power Rails

Modules are secured to the Power Rail using Mid Clamps and End Clamps, both of which use 5/16" bolts and flange nuts. The bolt length is dependent on the thickness of the Modules in use.

Due to the fixed tilt nature of the Multi-Pole Mount, it is extremely important that Modules are supported and held in place by a minimum of one person while the second person secures the End and/or Mid Clamps and attaching hardware to the Power Rail in such a manner as to securely hold the Modules in place.

Install the southern most Modules first and work in a northern direction. This provides a measure of safety as the southern Modules can help hold the next in-line northern Modules in place during installation.

These instructions include two types of clamping hardware. The “Standard End and Mid Clamps” (step B1), and the “RAD™ Clamps” (step B2).

The importance of correctly installing End and Mid Clamps:

Regardless of which hardware is used (Standard or RAD), there is only one correct method of installing End Clamps and Mid Clamps and it must be followed. If the correct method is not followed, the impending results could lead to personal injury, structural failure, and/or damaged components. See Figure 7-2 for proper method of installation for an End Clamp and Figure 7-3 for the Mid Clamp. Refer to these figures during the installation of the Modules to prevent any undue problems associated with an improper installation.

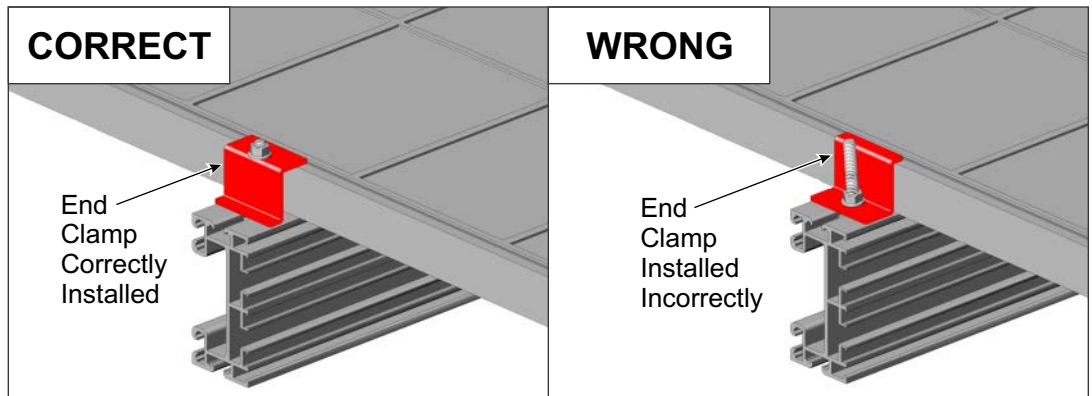

Figure 7-2: Correct and Wrong methods of installing an End-Clamp

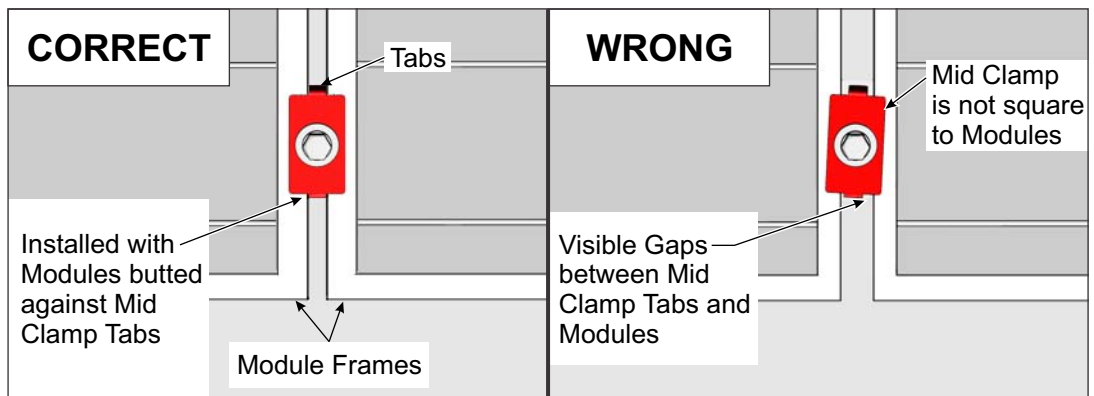

Figure 7-3: Correct and Wrong methods of installing a Mid Clamp

WARNING:
This is a two person activity. In addition to the difficulties related to working with a sloped rack, Modules are heavy. One person should hold and align the modules while a second person secures the Modules with clamping hardware. Failure to do so could lead to serious personal injury and/or damaged components.

Measure and Mark Module Positions on the Power Rails

- A. Make alignment marks for the Modules on the southern end of the Power Rail. From the southern end of each Power Rail, measure northward 1-1/2" and make a mark. Align the southern edge of the Modules to this mark.

B1. Using Standard Hardware End and Mid Clamps

Installing End Clamps:

- A. While one person positions and holds in place the first southernmost Module and aligns it to the 1-1/2" mark on the Power Rail, the second person measures and centers the Module lengthwise over the Power Rails, leaving about 20% of the Module length extending beyond the ends of the Power Rails.
- B. Insert one 5/16" x 2, 2-1/4, 2-1/2, or 2-3/4" carriage bolt (bolt length is dependent on depth of Module frame) into the top slot of the Power Rail, pushing the bolt against the module frame.
- C. Install the End Clamp onto the carriage bolt. Thread 5/16" flange nut onto carriage bolt and tighten. **Torque End Clamps to 14-16 ft.-lbs.** (See Figures 7-2 and 7-4)

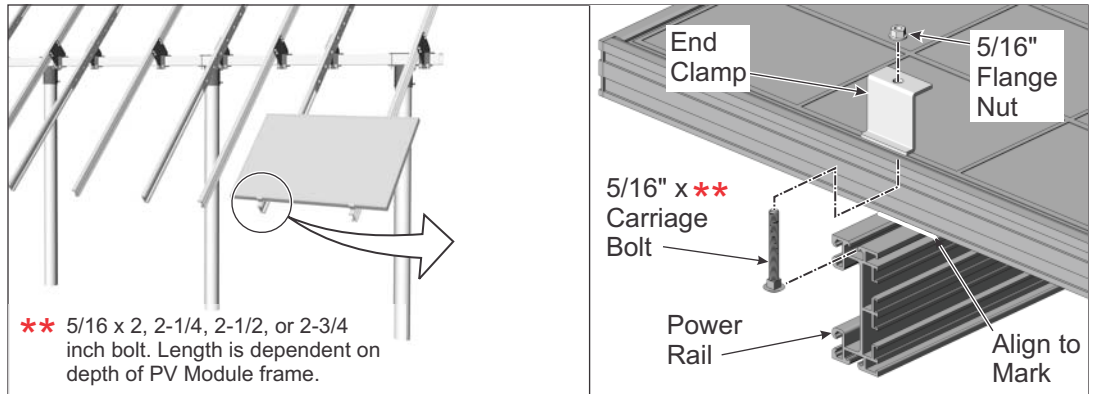

Figure 7-4: Installing Modules using Standard Hardware End-Clamp

Installing Mid Clamps:

- A. Before placing the next in-line Module onto the Power Rails, first pre-load the 5/16" x 2, 2-1/4, 2-1/2, or 2-3/4 inch carriage bolts (bolt length is dependent on depth of Module frame) into the northern end of the Power Rail, sliding the bolts southward adjacent to the previously installed southern Module. (See Figure 7-5)
- B. Place the next in-line Module onto the Power Rails, aligning it (east to west) with the previously installed southern Module and resting upon the 5/16" carriage bolts.
- C. Install one Mid Clamp on each of the 5/16" carriage bolts. Be sure that the tabs of the Mid Clamp rests between the two Modules. Secure each of the Mid Clamps with a 5/16" flange nut. **Torque Mid Clamps to 14-16 ft.-lbs.** (See Figures 7-3 and 7-6)

NOTE:
 If using standard 5/16" carriage bolts for Mid Clamps, the bolts must be inserted into the Power Rail before installing next in-line northern Modules.
 If using RAD hardware, the hardware can be inserted anytime at any position along the Power Rail.

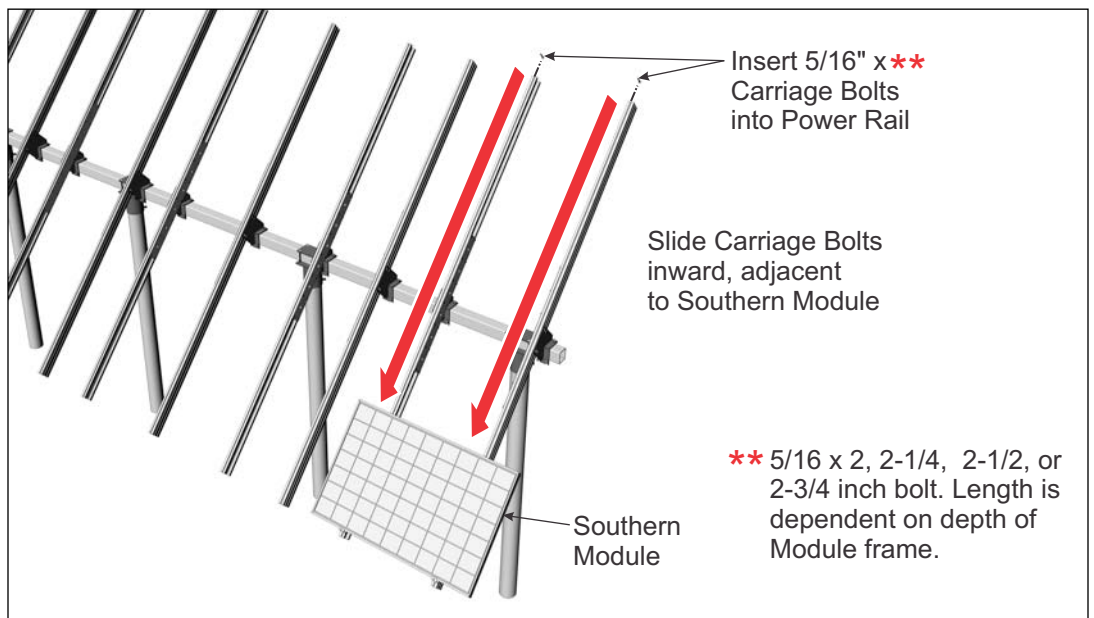

Figure 7-5: Pre-loading Standard Mid Clamp Hardware into Power Rail

WARNING:

The Tabs of the Mid Clamps must rest between the Modules. Failure to do so could lead to serious personal injury and/or damaged components and property.

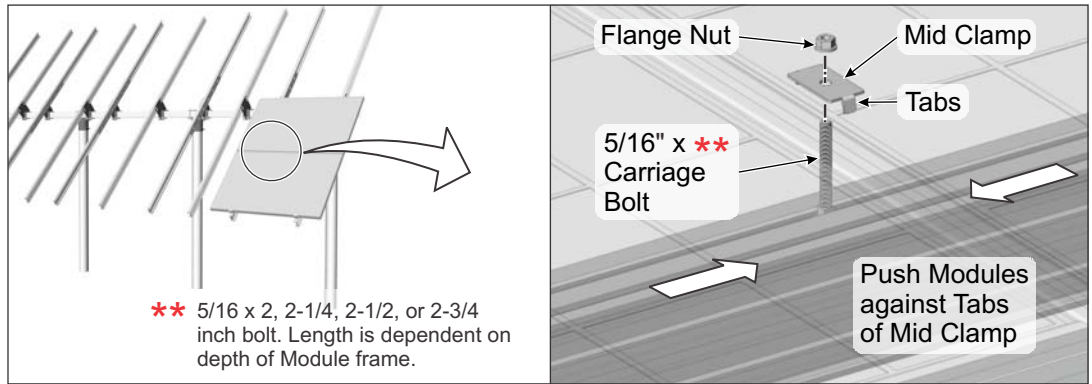

Figure 7-6: Installing Modules using Standard Hardware Mid Clamp

B2. Using RAD Hardware End and Mid Clamps

RAD bolts have a flat section on the threads of the bolt that correspond to the flat section of the mounting hole of the End and Mid Clamps. This flat aligns and secures the bolt in its locked position within the Power Rail. RAD can be inserted anywhere along the run of the Power Rail, not just the ends.

Installing End Clamps:

- A. While one person positions and holds in place the first southernmost Module, the second person measures and centers the Module lengthwise over the Power Rails, leaving about 20% of the Module length extending beyond the ends of the Power Rails.
- B. Insert 5/16" x 2, 2-1/4, 2-1/2, or 2-3/4 inch RAD bolt (bolt length is dependent on Module frame) into the Power Rail with the flat portion of the threads facing east. Rotate clockwise 90-degrees locking the bolt into the Power Rail. The flat portion of the threads should now be facing to the south. Push the bolt against the Module frame.
- C. Install the End Clamp by aligning the flat portion of its hole with flat portion of the RAD bolt. Thread 5/16" flange nut onto RAD bolt and tighten. **Torque End Clamps to 14-16 ft.-lbs.** (See Figures 7-2 and 7-7)

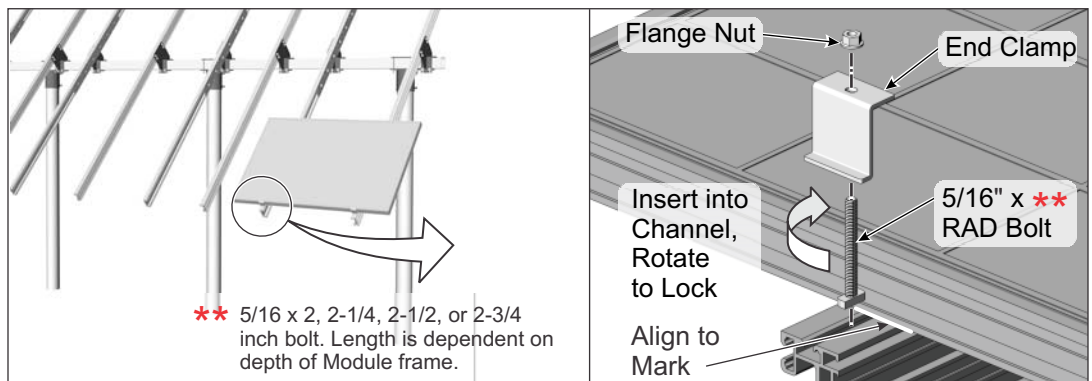

Figure 7-7: Installing Modules using RAD Hardware End-Clamp

WARNING:

Be certain that all Flange Nuts on End and Mid Clamps are tightened and torqued to the stated values. Failure to do so could lead to serious personal injury and/or damaged components and property.

WARNING:

The Tabs of the Mid Clamps must rest between the Modules. Failure to do so could lead to serious personal injury and/or damaged components and property.

Installing Mid Clamps:

- A. Insert 5/16" x 2, 2-1/4, 2-1/2, or 2-3/4 inch RAD bolts (bolt length is dependent on Module frame) into the Power Rail with the flat portion of the threads facing east. Rotate clockwise 90-degrees locking the bolt into the Power Rail. The flat portion of the threads should now be facing to the south.
- B. Place the next-in-line northern Module onto the Power Rails, aligning it (east to west) with the previously installed southern Module.
- C. Install the Mid Clamp by aligning the flat portion of its hole with flat portion of the RAD bolt, making certain the Mid Clamp tabs are between the two Modules. The northern most Module should now be resting on the tabs of the Mid Clamp. Thread 5/16" flange nut onto RAD bolt and tighten. **Torque End Clamps to 14-16 ft.-lbs.** (See Figures 7-2 and 7-8)

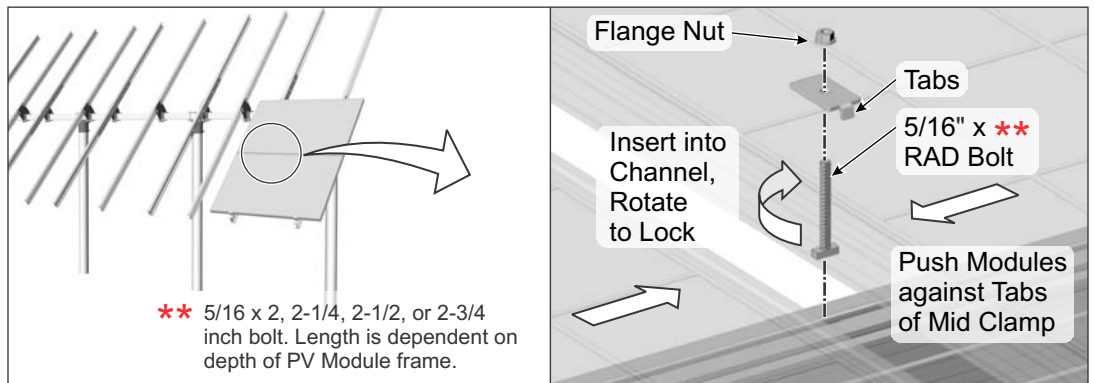

Figure 7-8: Installing Modules using a RAD Mid Clamp



4000-B Vassar Drive NE
Albuquerque, New Mexico 87107
USA

Telephone: 800.260.3792
Fax: 505.889.3548
Web Site: www.DPWSolar.com
E-mail: info@power-fab.com

© 2012 Preformed Line Products
PCN 121611-1
Version 1, Rev A