



**DPW** | SOLAR



**PREFORMED** LINE PRODUCTS



## MULTI-POLE MOUNT

Assembly Instructions

**step-by-step  
assembly and installation**

# The Multi-Pole Mount

## *A few words about the product*

The Multi-Pole Mount (MPM) is designed to mount on 3, 4, or 6 inch SCH40/80 galvanized steel pipe (installer supplied). The goal of the MPM design is to limit the number of ground penetrations while not exceeding 6 inch SCH40 pipe as the base structure.

Pipe size and foundation requirements are based on several factors including the array surface area, maximum design wind speed, exposure category, soil type, steepest expected tilt angle, and above-ground clearance.

For foundation and pipe size recommendations on a specific installation please contact us at:

Phone: 800-260-3792

Email: [info@power-fab.com](mailto:info@power-fab.com).

### WARNING

STAINLESS STEEL HARDWARE CAN GALL WHEN TIGHTENED TOO QUICKLY. INSTALLER SHOULD USE A SILVER GRADE ANTI-SEIZE COMPOUND PRIOR TO ASSEMBLING ANY STAINLESS STEEL HARDWARE. DO NOT USE AN IMPACT DRIVER. ALL OTHER DRIVER TYPES SHOULD BE SET TO LOW SPEED SETTINGS.

**WARNING:**  
Follow the procedures and precautions in these instructions carefully.

## *Assembly Instructions*

These instructions include information on assembling the product and are intended to be used by individuals with sufficient technical skills for the task. Knowledge and use of hand tools, measuring devices and torque values is also required.

Included in these instructions are various Notes, Cautions, and Warnings that are intended to draw your attention and assist in the assembly process and/or to draw attention to the fact that certain assembly steps may be dangerous and could cause serious physical injury and/or damage to components. Follow the procedures and precautions in these instructions carefully.

## *Required Tools*

- 1/2 inch wrench or socket for 5/16 inch module clamp hardware
- 9/16 inch wrench or socket for 3/8 inch hardware
- 3/4 inch wrench or socket for 1/2 inch hardware
- 3/16 inch hex tool for saddle bracket cone-point set screws
- Torque wrench
- Ratchet wrench
- Ratchet extension bar
- 3 to 6 foot level
- Framing square
- Tape Measure

Item	Description	Qty
1	U-bolt, (3/8") flat and lock washer, hex nut	2 per Pipe Cap
2	Pipe Cap	1 per Vertical Pipe
3	P8 Power Rail	2 per Rail Set
4	Universal End Clamp	4 per Rail Set
5	Carriage bolt (5/16" x 1"), flange nut	* 10 per Rail Set
6	Support Strut **	4 per Rail Set
7	Carriage Bolt (1/2" x 6" or 7"), flange nut	4 per Rail Set
8	Hex bolt (5/16" x 1"), flange nut **	4 per Rail Set
9	Rail Bracket	2 per Rail Set
10	Saddle Clamp with Set Screw (1/2" x 1")	4 per Rail Set
11	Strut Bracket	** 2 per Rail Set
12	End Clamp, (5/16" x ***) carriage bolt, flange nut	4 per Rail Set
13	Mid Clamp, (5/16" x ***) hex bolt, flange nut	2 per 3/8" gap between modules
14	RAD End-Clamp, (5/16" x ***) bolt, flange nut	4 per Rail Set
15	RAD Mid-Clamp, (5/16" x ***) bolt, flange nut	2 per 3/8" gap between modules

\* 6 per Rail Set if rail length is less than 86 inches  
 \*\* None used if rail length is less than 86 inches  
 \*\*\* 2", 2-1/4", 2-1/2", or 2-3/4" bolt. Length is dependent on depth of PV Module frame

Notes: 1. Option to install Mid Clamp with carriage bolt or RAD Mid Clamp  
 2. Option to install Universal End Clamp, End Clamp with carriage bolt or RAD End Clamp.

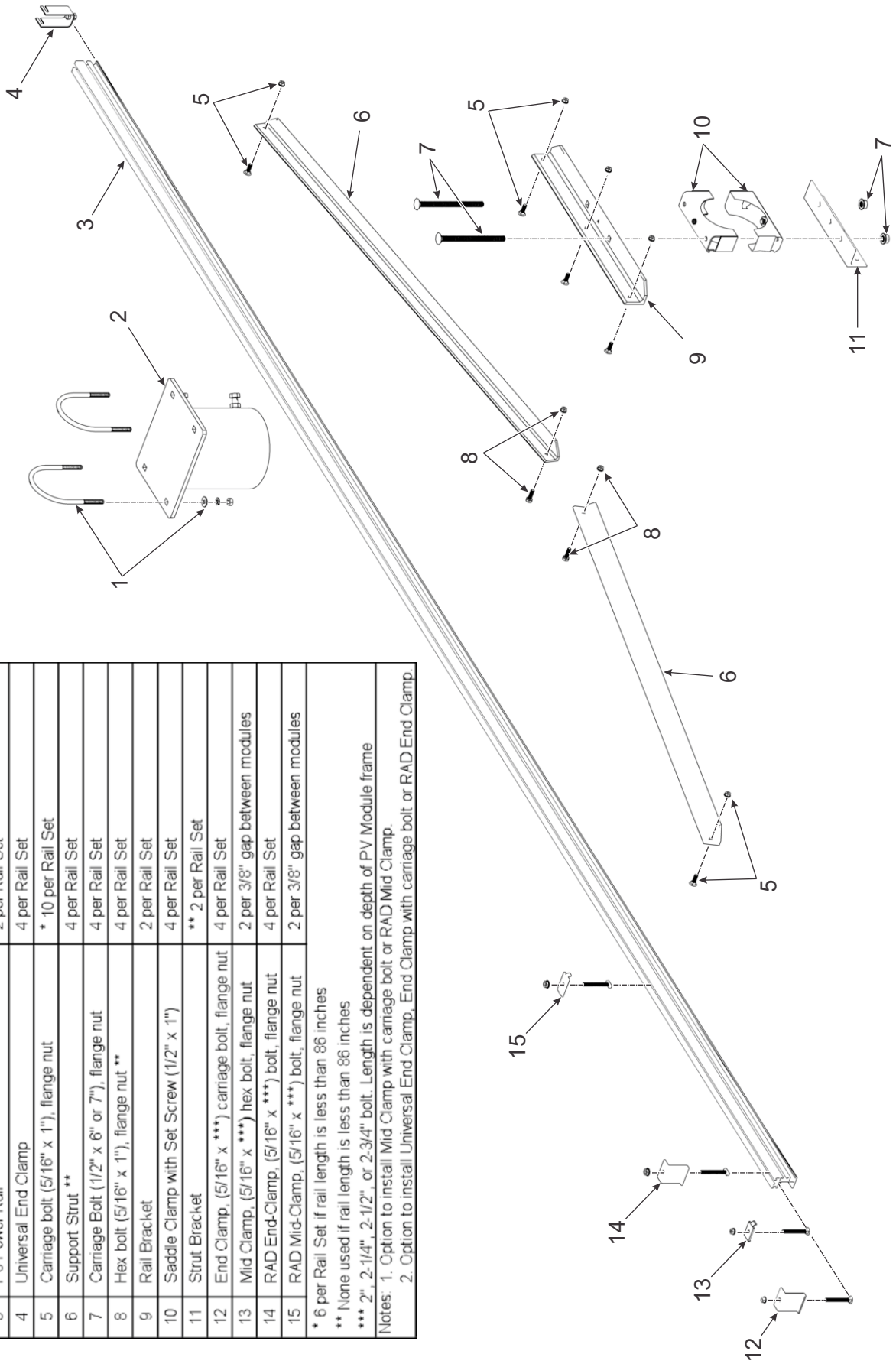

**Multi-Pole Mount Parts Identification**

# Assembly of the Multi-Pole Mount

**CAUTION:**

Before assembly, be certain that the vertical pipe installation has met the project requirements and the concrete footings have fully cured.

**NOTE:**

For foundation and pipe recommendations, fill out the MPM RFQ form and email to: info@power-fab.com

**WARNING:**

This is a two person activity. The Horizontal Pipes are heavy and unstable before secured. One person should hold the pipe while the other secures it to Pipe Caps. Failure to do so could lead to serious personal injury.

## Step 1: Install Pipe Caps on Vertical Pipes

Before installing Pipe Caps, verify that all Vertical Pipes are level to one another.

Install one Pipe Cap on each Vertical Pipe. The Pipe Caps have three or four set bolts each to secure the Pipe Cap to the Vertical Pipe. (See Figure 1-1)

- A. Slip the Pipe Cap on top of the Vertical Pipe and slide it down until it rests/bottoms out on top of the Vertical Pipe.
- B. Rotate the Pipe Cap(s) so the long dimension of the flange is aligned with the direction of the Horizontal Pipes (to be installed in Step 2).
- C. For now, finger-tighten the three or four set bolts so that the Pipe Cap is free to rotate as needed for Step 2.

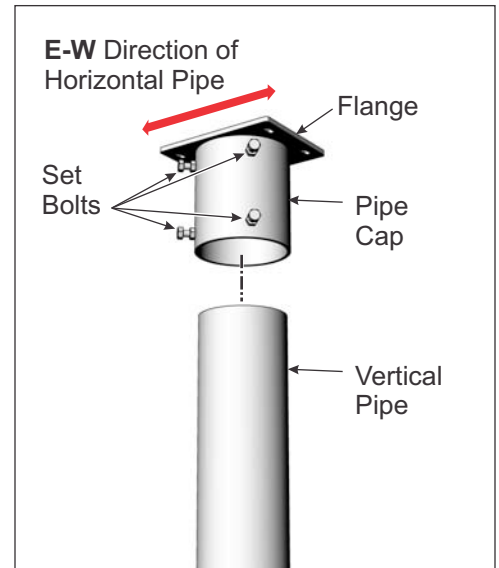

Figure 1-1: Installing Pipe Cap

## Step 2: Install Horizontal Pipes to Pipe Caps

Horizontal Pipes are secured to the Pipe Caps with two U-bolts and hardware. (See Figure 2-1)

- A. Lift and position the Horizontal Pipe onto the Pipe Caps, centering it along the run of Pipe Caps.
- B. Install two U-bolts over the Horizontal Pipe and into the Pipe Cap. If needed, rotate the Pipe Cap to align the mounting holes with the U-bolts.
- C. Secure U-bolts using the provided flat washers, lock washers and hex-nuts. **Torque to 25-30 ft.-lbs.**
- D. Tighten the three or four set bolts on each Pipe Cap. **Torque to 32-34 ft.-lbs. for 3/8" hardware or 55-60 ft.-lbs. for 1/2" hardware.**
- E. Repeat for additional Pipe Caps.

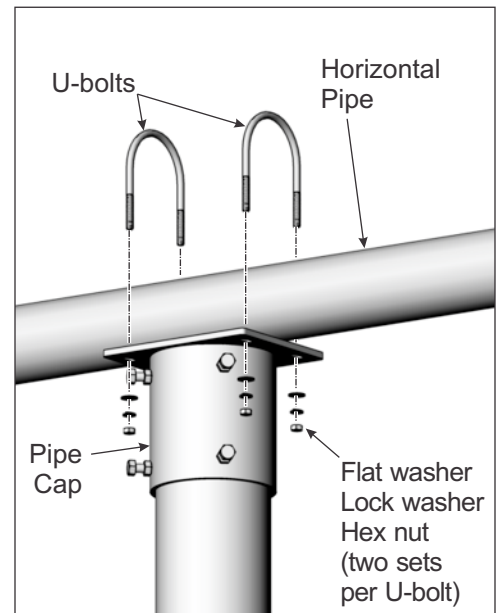

Figure 2-1: Installing Horizontal Pipe

**CAUTION:**

Use care while working around the structure during assembly. There could be components that create hazards or obstruct free movement causing serious bodily injury. Many are at head/eye level. Move slowly and with care around the work area.

**Step 3: Attaching the Rail Bracket to the Power Rail**

Attach one Rail Bracket to each of the Power Rails using 5/16 inch carriage bolts and flange nuts.

- A. Measure the length of the Power Rail, divide the number in half and mark its center.
- B. Insert three 5/16 inch carriage bolts into the Power Rail channel. Slide them towards the center mark of the rail. (See Figure 3-1)
- C. Align the center of the Rail Bracket to the center mark on the Power Rail and the three carriage bolts. Secure with flange nuts. **Torque to 14-16 ft-lbs** (See Figure 3-2)

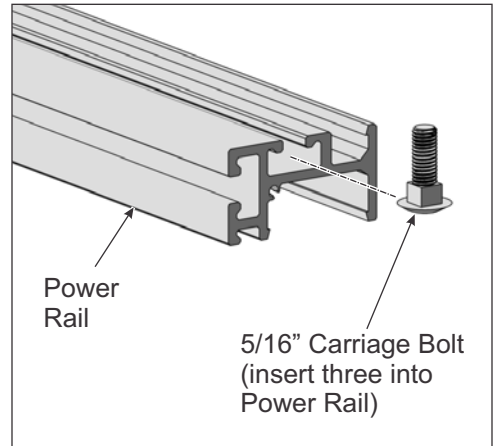

Figure 3-1: Inserting Carriage Bolts into Power Rail

**NOTE:**

Be sure that the Rail Bracket is properly oriented to the Power Rail.

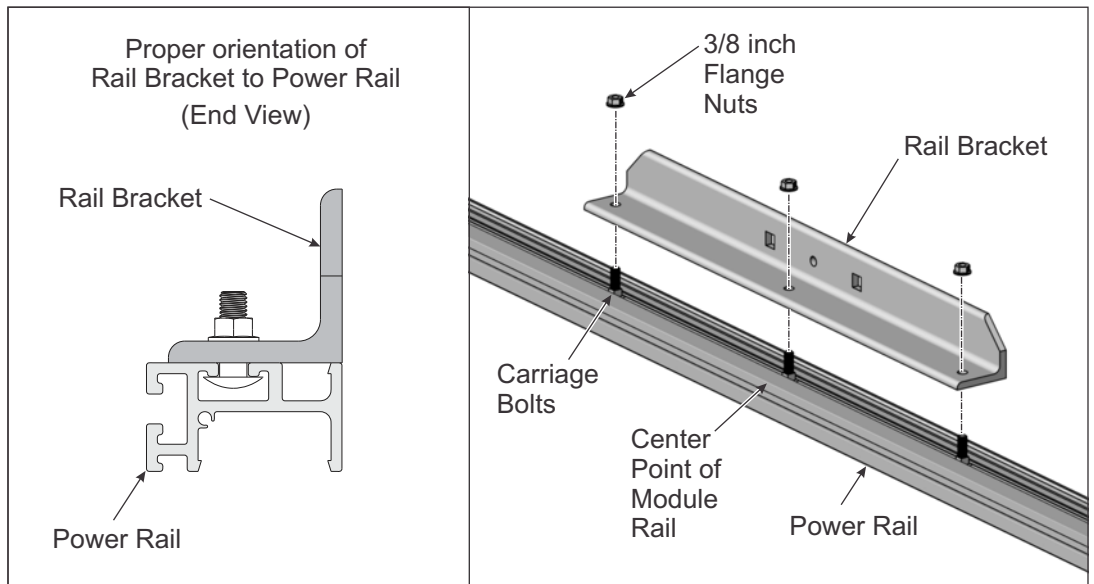

Figure 3-2: Installing Rail Bracket

**WARNING:**

This is a two person activity, because the Power Rail is unstable before it's secured. One person should steady the Power Rail while the other secures it. Failure to do so could lead to serious personal injury.

**NOTE:**

The Saddle Brackets are identical. The terms "Upper" and "Lower" have been used to clarify assembly instructions.

**NOTE:**

Strut Brackets may not be required if Module Rails do not exceed 86 inches in overall length.

**Step 4: Installing the Rail Set to the Horizontal Pipe**

Each Rail Set is secured to the Horizontal Pipe using two Saddle Clamps, one Strut Bracket and two 1/2 inch carriage bolts per Rail Set.

Rail Sets are positioned across the Horizontal Pipe while avoiding the Vertical Pipe joints and U-bolts. The span between each Rail Set is dependent on the size of photovoltaic (PV) Modules to be used. It is recommended that Rail Sets be positioned inboard 15-20% from the outer edges of the PV Modules. Measure the Modules and determine this span before proceeding.

Use care when installing the Saddle Clamps to ensure proper alignment and positioning as shown in Figure 4-1 below.

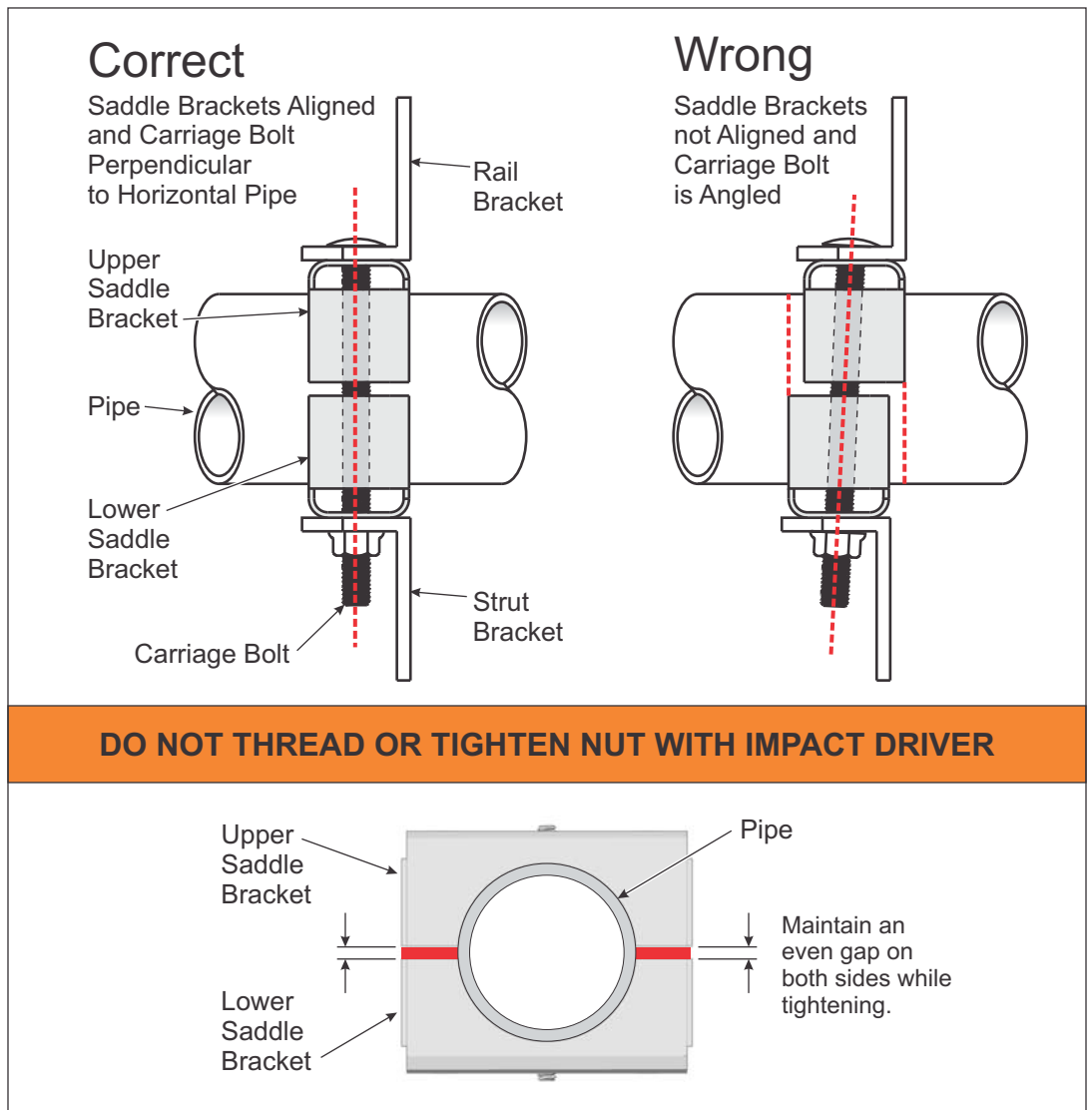
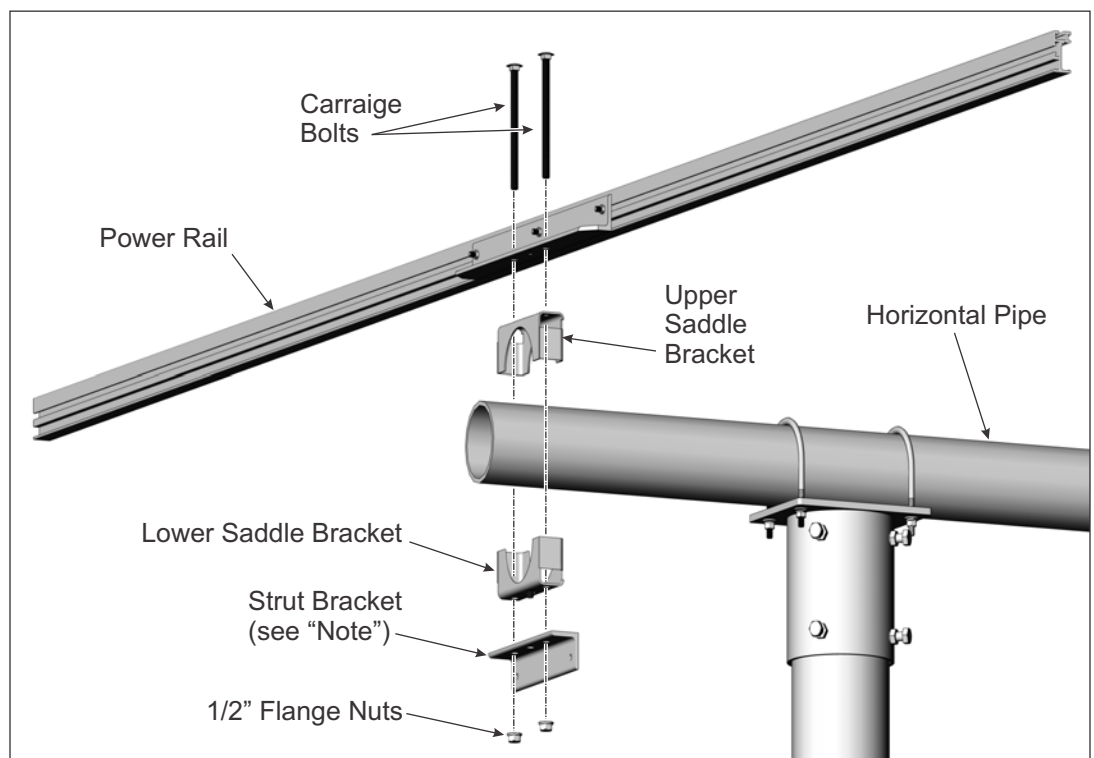

Figure 4-1: Alignment and Tightening of Saddle Brackets

- A. Using a tape measure, mark the desired Power Rail positions along the Horizontal Pipe (15-20% inboard of the module edges).
- B. Insert the two carriage bolts into the square holes of the Rail Bracket.
- C. Place the Upper Saddle Bracket on top of the Horizontal Pipe, aligning it with a layout mark made in Step 4A and hold it in place.
- D. Lift the Rail Set onto the Horizontal Pipe, straddling the carriage bolts on either side of the Horizontal Pipe while passing them through the Upper Saddle Bracket.
- E. Align and install the Lower Saddle Bracket onto the carriage bolts. Hold it in place and align and install the Strut Bracket. Secure with two 1/2 inch flange nuts tightening them evenly from side-to-side to maintain an even gap between both ends of the upper and lower Saddle Brackets. **Torque both nuts to 60-70 ft.-lbs.** (See Figures 4-1 and 4-2)

Although the Saddle Clamps include Set Screws, do not tighten them at this time. They will be tightened after the assembly is complete and the PV Module angle has been set (see Step 8).



**NOTE:**  
Power Rails that do not exceed 86 inches in overall length do not require or include Strut Brackets.

Figure 4-2: Installing and Securing Rail Set to Horizontal Pipe

**NOTE:**

Module Rails that do not exceed 86 inches in overall length may not require or include Support Struts.

**Step 5: Attach Support Struts to Power Rail and Strut Bracket**

Attach two Support Struts per Power Rail (one on each end) using 5/16 inch carriage bolts and flange nuts.

- A. Attach one end of the Support Strut to the Power Rail by first inserting one 5/16 inch carriage bolt in the channel of the Power Rail. (See Figure 5-1)
- B. Position and secure the Support Strut to carriage bolt using a 5/16 inch flange nut. For now, finger tighten only. (See Figure 5-2)

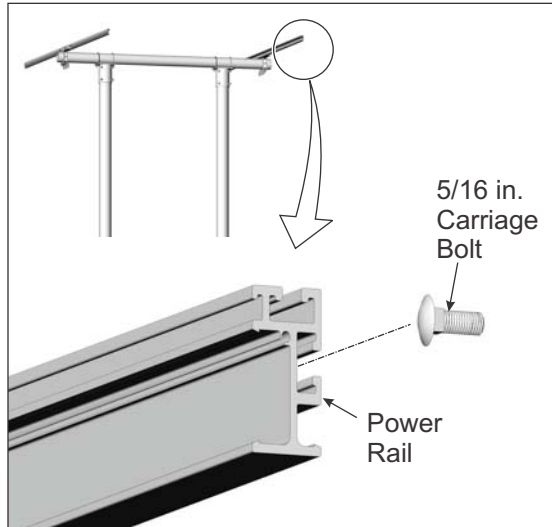

Figure 5-1: Inserting Carriage Bolt

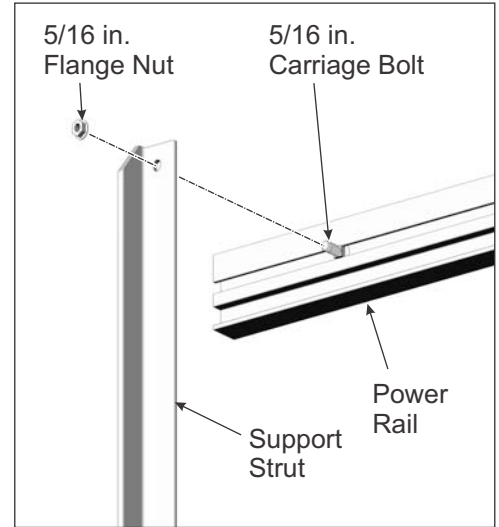

Figure 5-2: Attaching Support Strut

- C. Attach Support Struts to Strut Bracket by pivoting the free-end upward to align mounting hole with Strut Bracket. Insert and finger tighten 5/16 x 1 inch hex bolt with 5/16 inch flange nut. Level Power Rail before tightening. (See Figure 5-3)

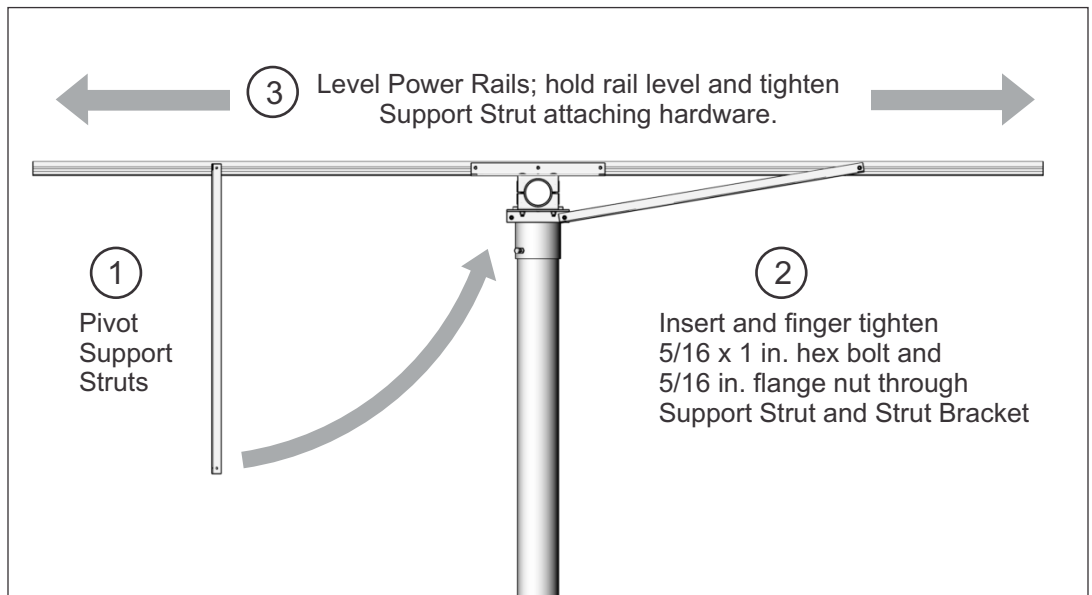

Figure 5-3: Leveling Power Rail and Securing Support Strut to Strut Bracket

- D. Tighten all Support Strut attaching hardware. **Torque to 14-16 ft.-lbs.**

**WARNING:**

This is a two-person activity. One person should hold the Power Rail as the other loosens, adjusts and re-tightens the flange nuts. Failure to do so could lead to personal injury.

**Step 6: Leveling and Preparing Multi-Pole Mount for PV Modules**

Prior to installing PV modules, the Power Rail assemblies must be level. Use a minimum 6-foot length level to check for level in all directions.

Check for level by positioning a level on top of each Power Rail. To adjust, one person holds one end of the Power Rail and the level, while another gently loosens the 1/2" flange nuts securing the Strut Brackets to the Saddle Clamps. Loosen the 1/2" nuts just enough to allow the Power Rail to rotate on the Horizontal Pipe. Rotate until level. Once level, re-tighten the 1/2" flange nuts. **Torque to 60-70 ft.-lbs.** (See Figure 6-1)

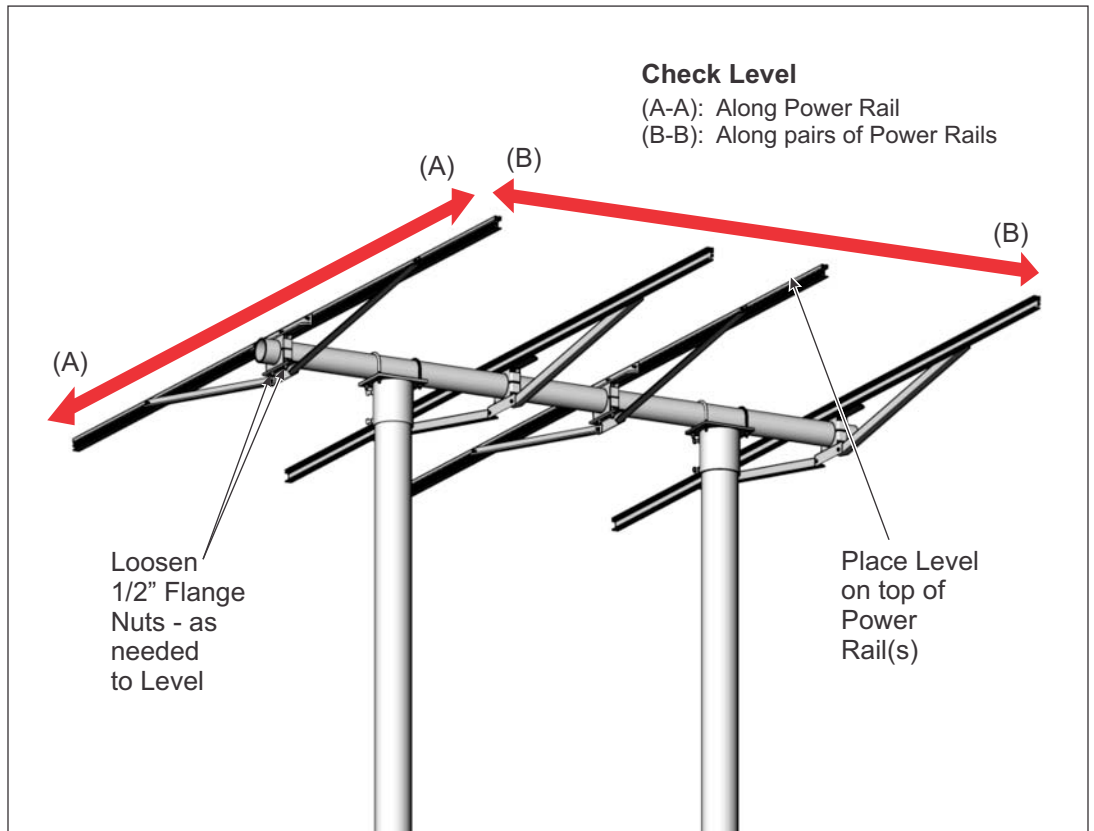

Figure 6-1: Leveling Power Rails prior to PV Module Installation

**NOTE:**

Because hardware is dependent on particular features and system design, your hardware may appear different from the hardware in these instructions.

**Step 7: Installing Modules to Power Rails with Module Clamps**

Start with the southern most PV Modules and work in a northern direction. This provides a measure of safety as the previously installed southern Modules hold the next in-line northern Module during installation. Modules are secured to the Power Rail using Mid Clamps and End Clamps, both use 5/16" bolts and flange nuts.

These instructions include three options of clamping hardware. They are "Universal End Clamp" (step B1), "Standard End Clamp" (step B2), and "RAD™ Clamps" (step B3).

- A. Place exterior Module on two Power Rails, centering it lengthwise. Use a square to square-up Module to Power Rails.
- B1. For use with "**Universal End Clamps**": Position Universal Clamp underneath the module with notches facing the outside edge of the module, and rail centered between 'forks' of the clamp. Slide clamp notches towards module flange until the flange bottoms out in the notches. Tighten 5/16" bolt on bottom of universal end clamp. **Torque to 14-16 ft.-lbs.** Repeat for both end clamps. (See Figure 7-1)

**WARNING:**

This is a two person activity. In addition to the difficulties related to working with a sloped rack, PV Modules are heavy. One person should hold and align the modules while a second person secures modules with clamping hardware. Failure to do so could lead to serious personal injury and/or damaged components.

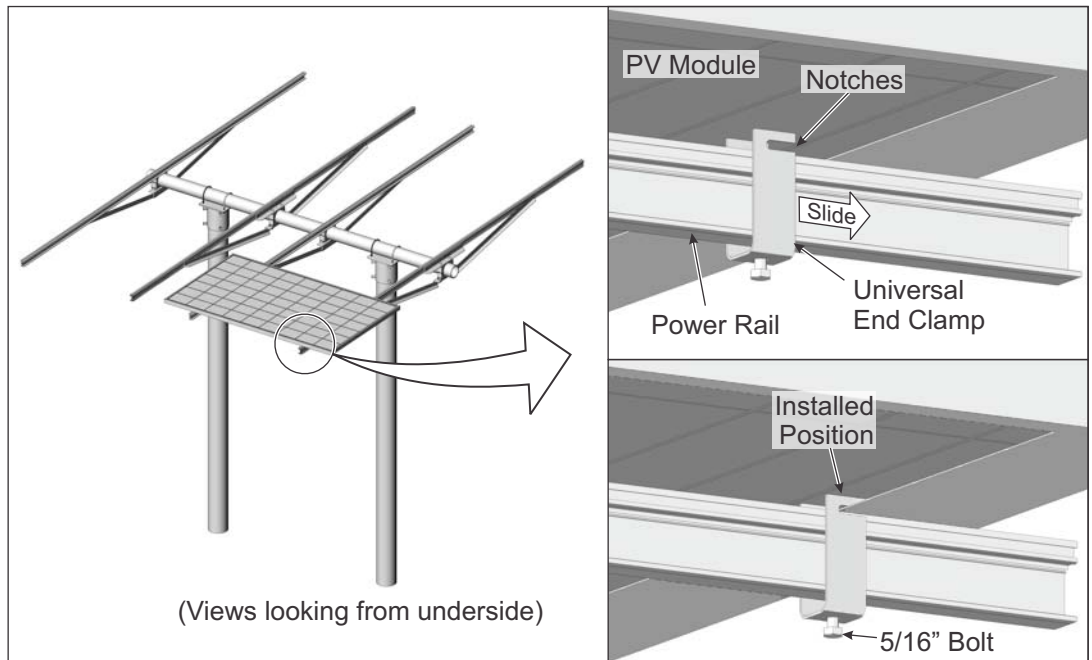
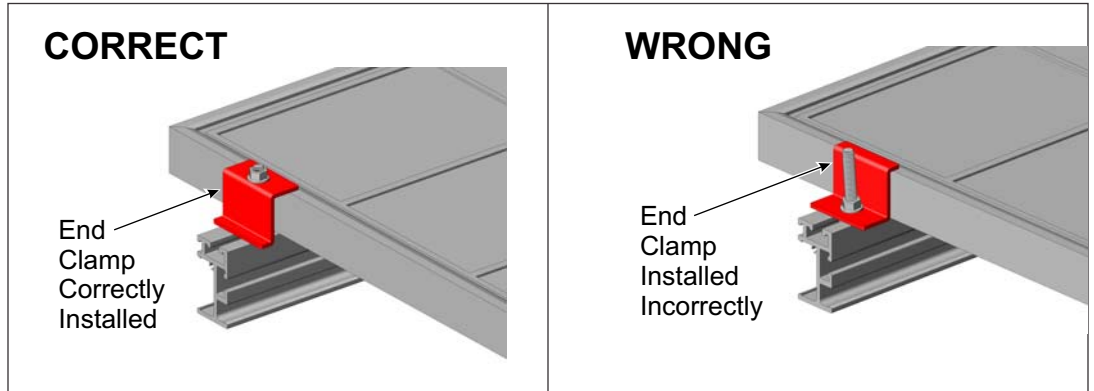

Figure 7-1: Installing PV Modules using Universal End Clamp

B2. For use with “**Standard End Clamps**”: Standard End Clamps must be installed as shown in Figure 7-2.



*Figure 7-2: Correct and Wrong methods of installing Standard End-Clamp*

Insert one 5/16” x 2, 2-1/4, 2-1/2, or 2-3/4” carriage bolt into the top slot of the Power Rail. Push the bolt until flush with edge of module frame. Position end clamp with hole facing upwards and center hole over bolt. Seat end clamp over bolt flush with module frame. Thread 5/16” flange nut onto clamp and tighten. When desired alignment is obtained, tighten the nut and end clamp. **Torque End Clamps to 14-16 ft.-lbs.** (See Figure 7-3)

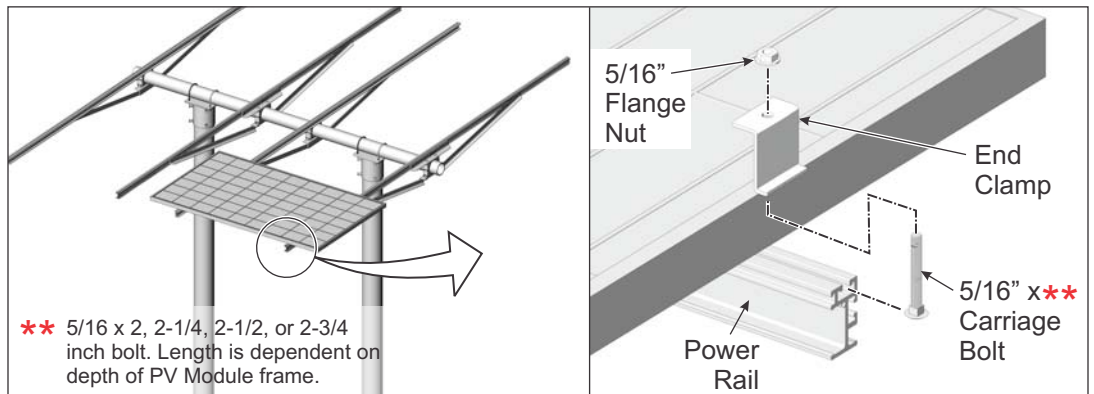

*Figure 7-3: Installing PV Modules using Standard End-Clamp*

B3. For use with “**RAD Hardware**”. The process is much the same as in step B2. The difference is RAD bolts can be inserted anywhere along the run of the Power Rail, not just the ends of the rail as shown in Figure 7-3.

Although this step demonstrates installing a *Mid-Clamp*, the procedure for an *End-Clamp* is much the same when using RAD hardware.

Insert RAD bolt into Power Rail and rotate 90-degrees to lock into rail. Install module clamp (End or Mid-Clamp) onto bolt by aligning the flat portion of the clamp with that of the bolt. Thread 5/16" flange nut onto clamp and tighten. When desired alignment is obtained, tighten the nut and end clamp. **Torque End Clamps to 14-16 ft.-lbs.** (See Figure 7-4)

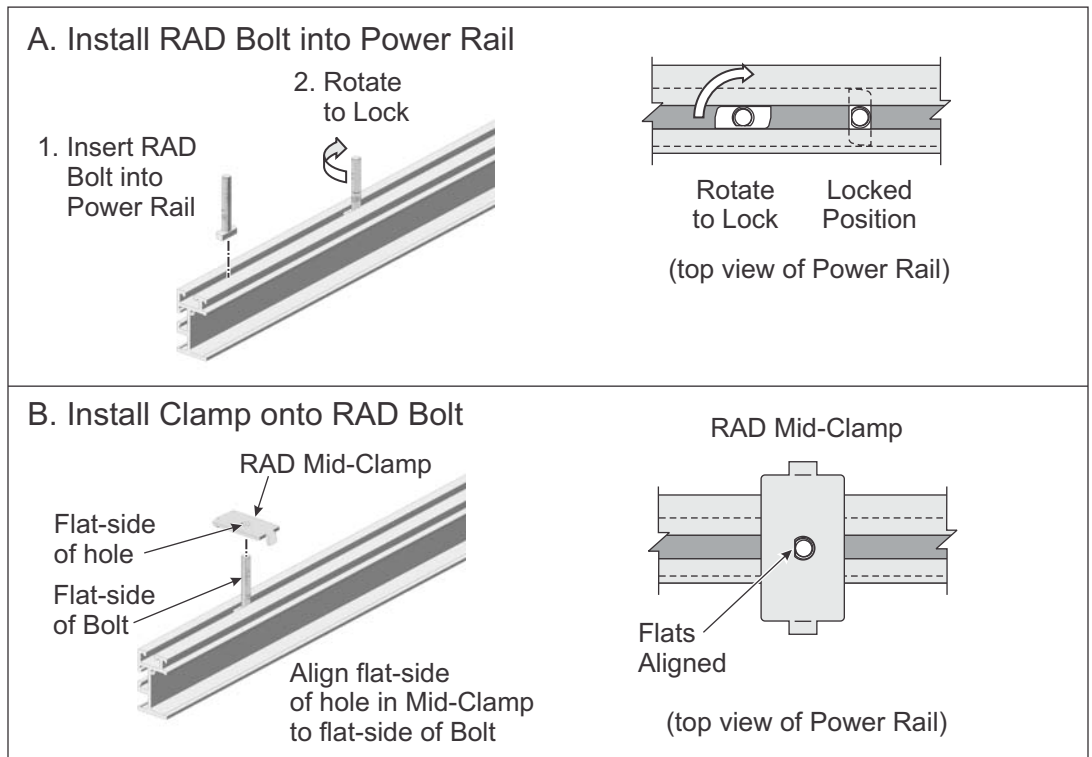

Figure 7-4: Installing PV Modules using RAD Hardware

**NOTE:**

If using standard 5/16" carriage bolts for Mid Clamps, the bolts must be inserted into the Power Rail before installing interior PV Modules.

If using RAD hardware, the hardware can be inserted anytime at any position along the Power Rail.

**NOTE:**

It may be necessary to shift PV Modules off-center of the Power Rails for clearance purposes. In such cases, shifting the PV Modules 2 to 4 inches in either direction is recommended.

**WARNING:**

Be certain that all Flange Nuts on End and Mid Clamps are tightened and torqued to the stated values. Failure to do so could lead to serious personal injury and/or damaged components and property.

**Installing interior Modules.**

- A. Before placing an interior Module onto the Power Rails, first insert 5/16" x 2, 2-1/4, 2-1/2, or 2-3/4 inch carriage bolts (bolt length is dependent on depth of PV Module frame) into the Power Rail, sliding the bolts inward adjacent to the previously installed exterior Module. (See Figure 7-5)

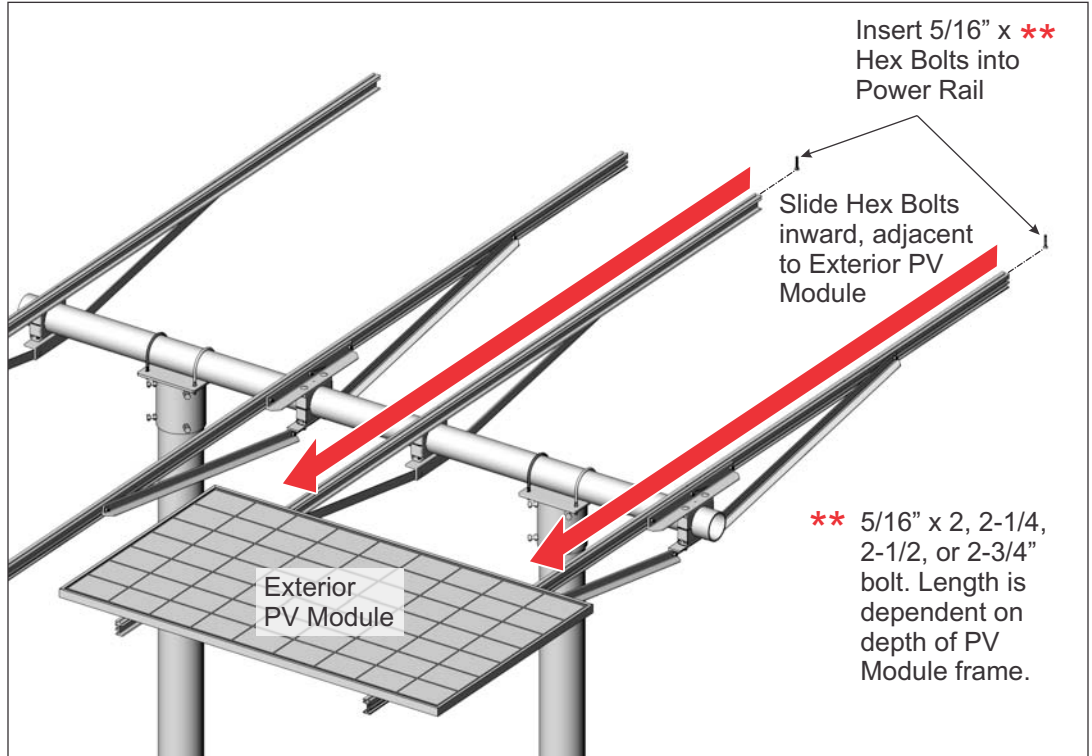

Figure 7-5: Inserting Mid Clamp Hardware

- B. Place the interior Module onto the Power Rails, aligning it with the previously installed exterior Module. Position it adjacent to 5/16" bolts and the previously installed exterior Module.
- C. Use a square to square-up Module to Power Rails.
- D. Install one Mid Clamp on each of the 5/16" bolts that are between each of the interior Modules. Be sure that the tabs of the Mid Clamp rest between the two Modules. Secure each of the Mid Clamps with a 5/16" flange nut. **Torque Mid Clamps to 14-16 ft.-lbs.** (See Figure 7-6)

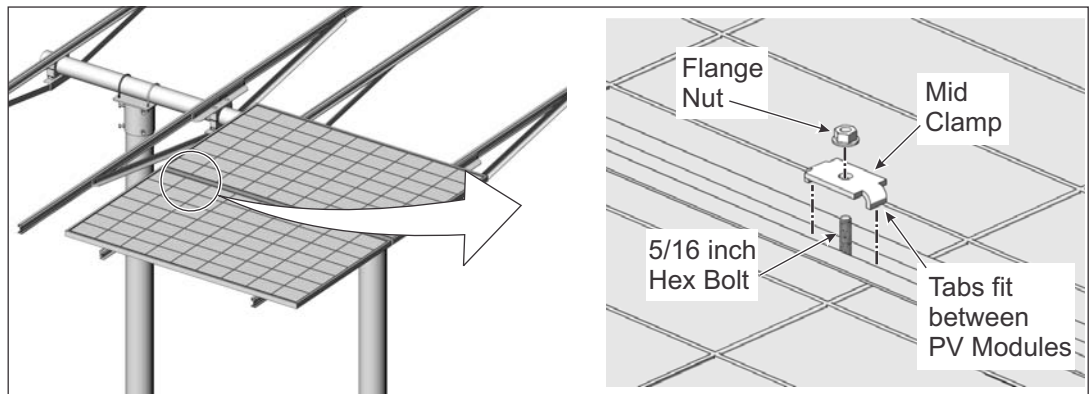

Figure 7-6: Installing Mid Clamps

**WARNING:**

Before setting the tilt angle, make certain all End and Mid Clamps have been fully tightened. Failure to do so could lead to serious personal injury and/or damaged components.

**Step 8: Setting the Tilt Angle**

This step describes how to adjust the tilt angle of the PV Modules by rotating the structure of panels around the Horizontal Pipe.

- A. Gently loosen the 1/2 inch flange nuts on carriage bolts just enough to allow each Rail Set to rotate around the horizontal pipe, allowing the PV Modules to tilt. (See Figure 8-1)

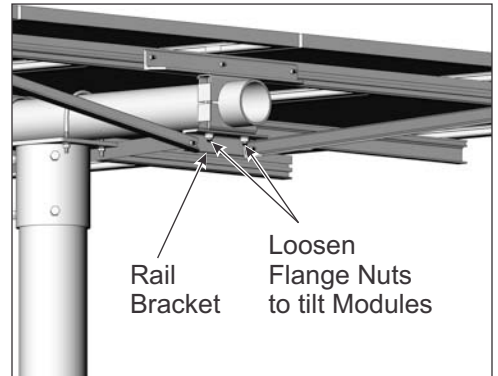

Figure 8-1: Loosening Flange Nuts

- B. Tilt the PV Modules to the pre-determined angle and hold in place. (See Figure 8-2)

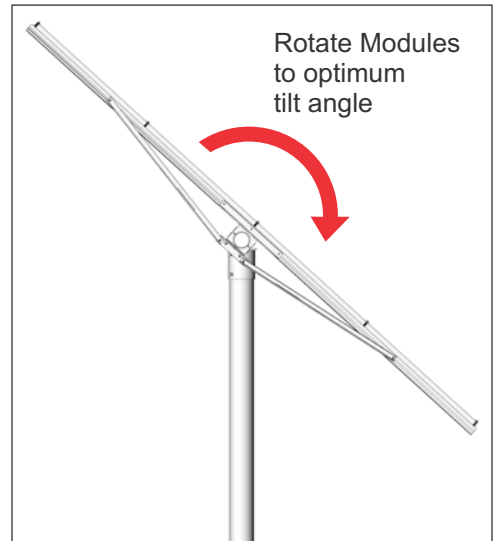

Figure 8-2: Adjusting Tilt Angle

- C. Re-tighten all of the 1/2 inch flange nuts on each of the carriage bolts. **Torque all to 60-70 ft-lbs.** (See Figure 8-3)
- D. Tighten the knurled-point Set Screws (top & bottom) of the Saddle Clamps. (See Figure 8-4)

**WARNING:**

Be certain that all Flange Nuts are re-tightened. Failure to do so could lead to serious personal injury and/or damaged components.

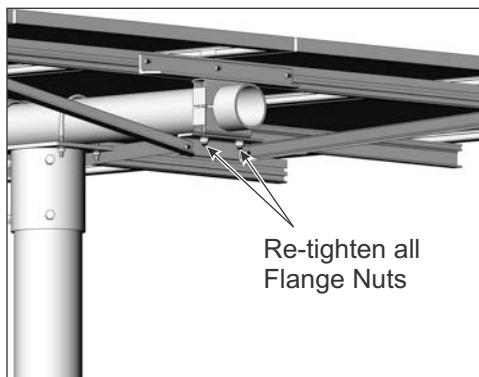

Figure 8-3: Re-tighten Flange Nuts

**WARNING:**

Be sure to tighten the Saddle Clamp Set Screws. Failure to do so could lead to serious personal injury and/or damaged components.

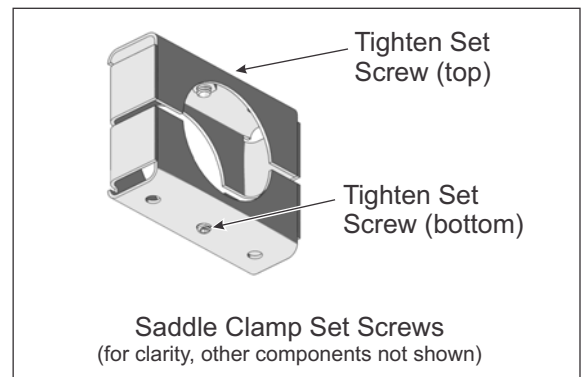

Figure 8-4: Tighten Set Screws



4000-B Vassar Drive NE  
Albuquerque, New Mexico 87107  
USA

Telephone: 800.260.3792  
Fax: 505.889.3548  
Web Site: [www.DPWSolar.com](http://www.DPWSolar.com)  
E-mail: [info@power-fab.com](mailto:info@power-fab.com)

© 2011 Preformed Line Products  
PCN 081711-3  
Version 3, Rev B