

Module		
Type	Width	Length
G	37-42"	61-67"

Ballasted Roof Mount for 6 Modules (BRM6) For Module Type G

ASSEMBLY INSTRUCTIONS

**step-by-step
assembly and installation**

Ballasted Roof Mount for 6 Modules (BRM6) For Module Type G

CAUTION:

Do not attempt to install the Ballasted Roof Mount system on any roof with a pitch greater than 1/12 (approximately 5 degrees) as this could lead to a catastrophic structural failure and severe personal injury or death.

WARNING:

Follow the procedures and precautions in these instructions carefully.

A Few words about the product

The Ballasted Roof Mount is a non-penetrating structure, so the structure does not get screwed, bolted or otherwise fastened to the roof substrate. Instead, it is weighted i.e., (held in place) on the roof substrate using concrete cap-blocks as ballast.

In its standard design, the BRM is rated and warranted to withstand 90 MPH maximum wind speeds at Exposure Category C (assumes minimum 4" x 8" x 16" - 25 lbs. cap blocks are used).

CAUTION

The Ballasted Roof Mount system is to be installed over *adhered* or *fixed roof surfaces* only. If additional roof protection materials, including slip sheets, drain mats or sacrificial layers, are added under the Ballasted Roof Mount structure, those materials must be *adhered* to the main roofing material and *trimmed* so no more than 6-inches of slip sheet, drain mat or other sacrificial material extends beyond the perimeter of any one of the Ballasted Roof Mount ballast trays.

If adhering of these materials is not possible, please contact DPW Solar engineering for additional review.

About these Assembly Instructions

These instructions...

- Are intended to be used by individuals with sufficient technical skills for the task. Knowledge and use of hand tools, measuring devices and torque values is also required.
- Include various precautions in the forms of Notes, Cautions, and Warnings. These are to assist in the assembly process and/or to draw attention to the fact that certain assembly steps may be dangerous and could cause serious personal injury and/or damage to components. Following the step-by-step procedures and these precautions should minimize the risk of any personal injury or damage to components while making the installation not only safe but an efficient process.

For questions on a specific installation contact us at:

Phone: 800-260-3792

Email: info@power-fab.com

For DPW Solar approved Wiley Electronics grounding solutions, please visit www.we-llc.com

Required Tools

- 1/2 inch wrench or socket for 5/16 inch module clamp hardware
- Torque wrench
- Ratchet wrench
- Ratchet extension bar
- Framing square
- Tape Measure

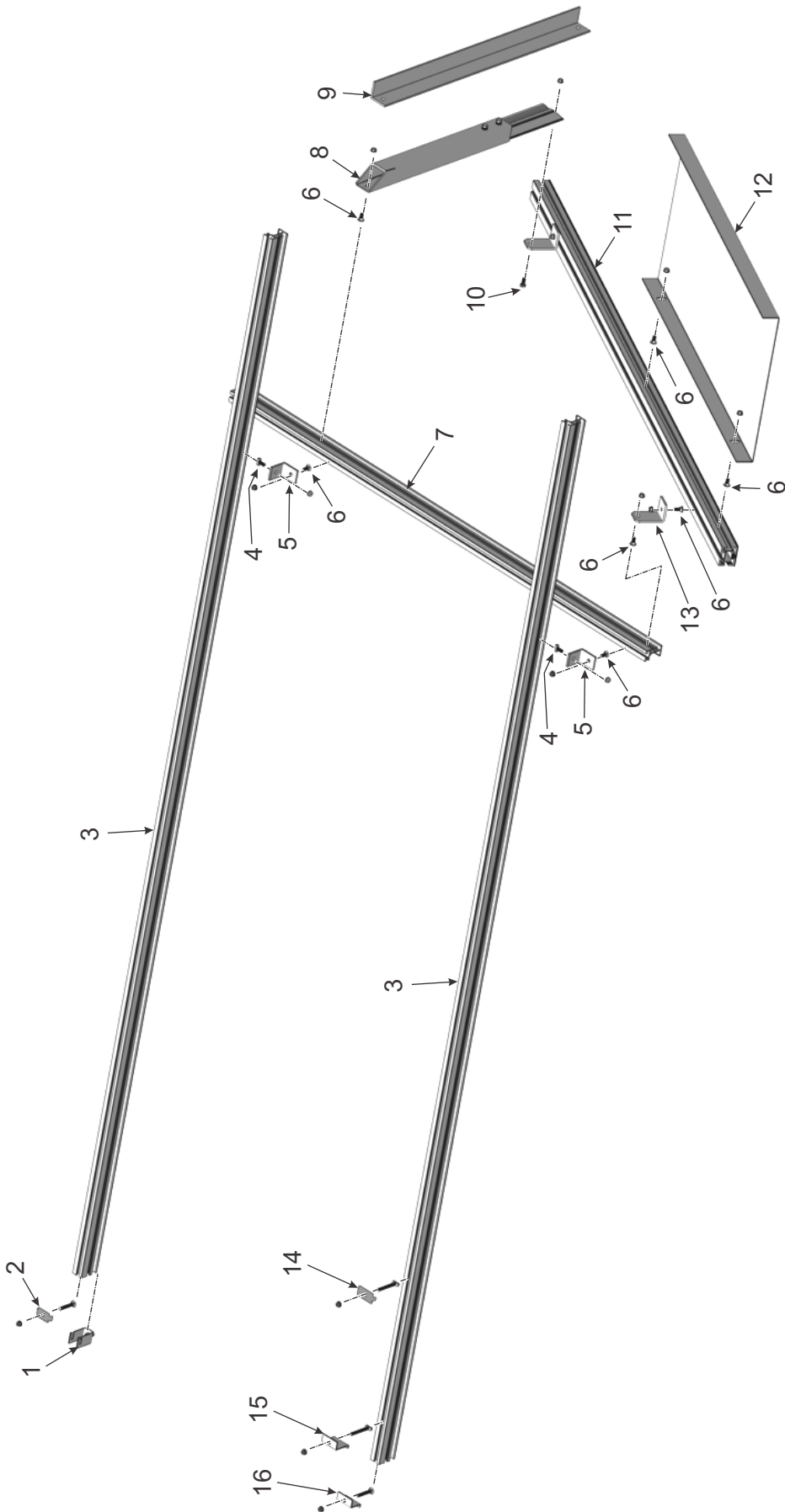

Item	Description	Qty
12	Ballast Pan	16 per Rack
13	Mounting Foot	8 per Rack
14	RAD Mid Clamp, (5/16" x *) bolt, flange nut (see Note 2)	10 per Rack
15	RAD End Clamp, (5/16" x *) bolt, flange nut (see Note 2)	4 per Rack
16	End-Clamp, (5/16" x *) carriage bolt, flange nut	4 per Rack

* 2, 2-1/4, 2-1/2, or 2-3/4" bolt. Length is dependent on depth of PV Module frame

** Leg type is design dependent. One-Piece or Telescoping leg type.

Notes: 1. Option to install Mid Clamp with carriage bolt or RAD Mid Clamp.
2. Option to install Universal End Clamp, End Clamp with carriage bolt or RAD End Clamp.

Item	Description	Qty
1	Universal End Clamp (see Note 1)	4 per Rack
2	Mid Clamp, (5/16" x *) carriage bolt, flange nut	10 per Rack
3	P8 Power Rail, Module Rail	2 per Rack
4	5/16" x 3/4" turn bolt, flange nut	8 per Rack
5	Rail Brackets	8 per Rack
6	5/16" x 3/4" carriage bolt, flange nut	56 per Rack
7	P8 Power Rail Strongback	4 per Rack
8	**Telescoping Leg	4 per Rack
9	**One-Piece Leg	4 per Rack
10	5/16" x 3/4" Hex bolt, flange nut	4 per Rack
11	Power Tube	4 per Rack

BRM6 Type G Parts Identification

Step 1: Attach the Ballast Pans to the Power Tube

There are four Ballast Pans per Power Tube Extrusion. They are secured to the Power Tube using 5/16" x 3/4" carriage bolts and flange nuts. The Ballast Pans have slotted mounting holes which provide vertical/elevational adjustments of the Power Tubes. This adjustability is useful when there are elevation changes due to undulations of the roof surface.

- A. Insert two of the 5/16" x 3/4" carriage bolts into the channel of the Power Tube. Be careful to properly position and orient the Power Tube. (See Figure 1-1)
- B. Position the Ballast Pan to align with the carriage bolts. Thread on the 5/16" flange nuts and finger tighten for now. (See Figure 1-2)
- C. Continue in this manner and install the remaining Ballast Pans.

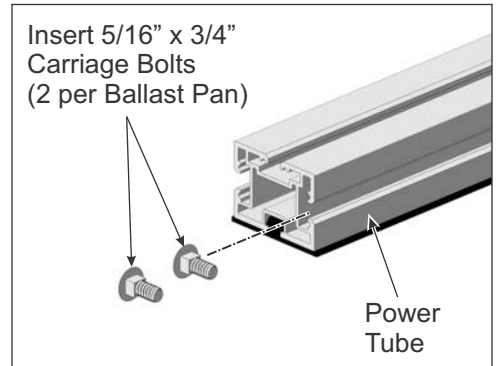

Figure 1-1: Pre-loading Carriage Bolts into the Power Tube

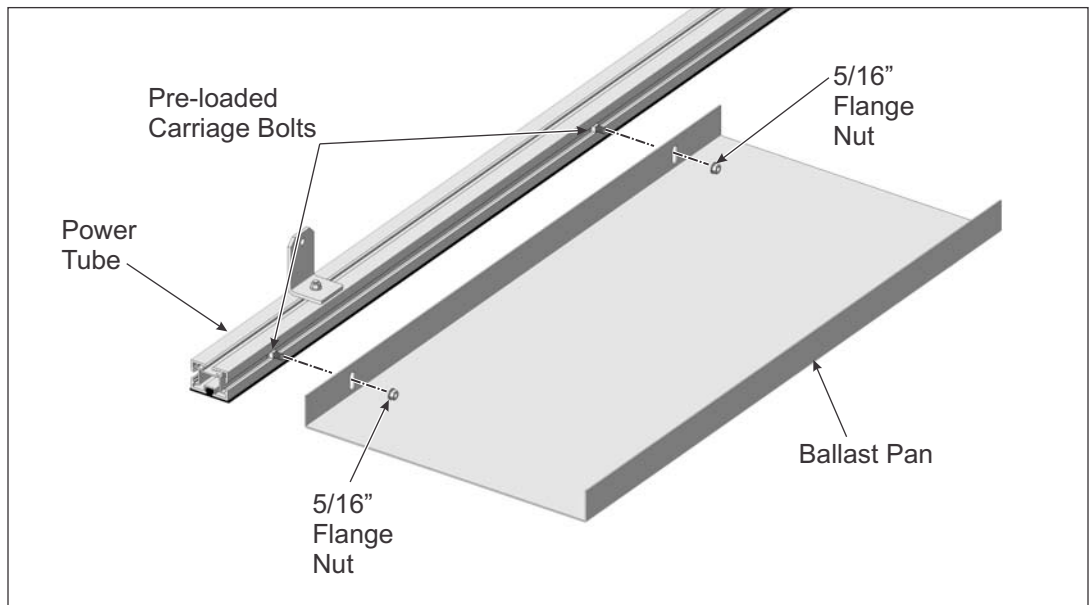

Figure 1-2: Attaching the Ballast Pans to the Power Tube

- D. Adjust the elevation of the Power Tubes as needed by shifting them within the slotted mounting holes of the Ballast Pan(s). Return and tighten each of the flange nuts. **Torque to 14-16 ft.-lbs.**

Step 2: Measure and Mark Attachment Points on the P8 Strongback

There are two important attachment points that must be measured and marked on the P8 Strongback. One mark indicates where the P8 Strongback attaches to the southern Mounting Foot and the other indicates where the Telescoping Leg attaches to the northern end of the P8 Strongback.

- A. From the southern end of the P8 Strongback, measure and make a mark 1-inch from the end. This is where the P8 Strongback will attach to the southern Mounting Foot. (See Figure 2-1)
- B. From the northern end of the P8 Strongback, measure and make a mark 14-inches from the end. This mark represents the furthest distance inboard from the northern end of the P8 Strongback that the leg can be mounted. The leg can be mounted anywhere within this 14-inch span, however if the leg must be mounted closer to the northern end of the P8 Strongback, the mounting point must be set inboard by 1-inch from the northern end.

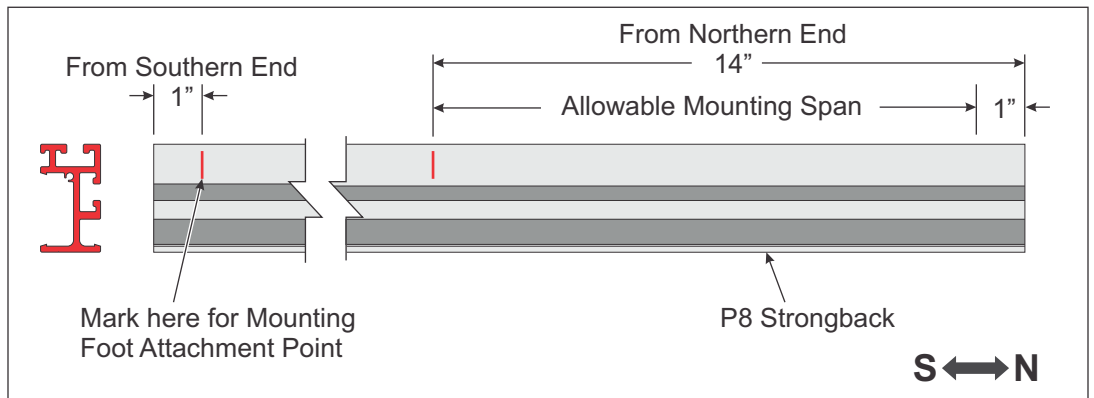

Figure 2-1: Measure and Mark Attachment Points on P8 Strongback

Step 3: Attach P8 Strongback to Southern Mounting Foot

The P8 Strongback is secured to the southern Mounting Foot using 5/16" x 3/4" carriage bolts and flange nuts. Hardware may vary depending on design-specific requirements.

- A. Refer to Figure 3-1 for P8 Strongback profile orientation.
- B. Slide one 5/16" x 3/4" carriage bolt into the P8 Strongback.
- C. Line up your mark on the P8 Strongback with the center of the southern Mounting Foot.
- D. Secure with 5/16" flange nut. Finger tighten for now. (See Figure 3-2)

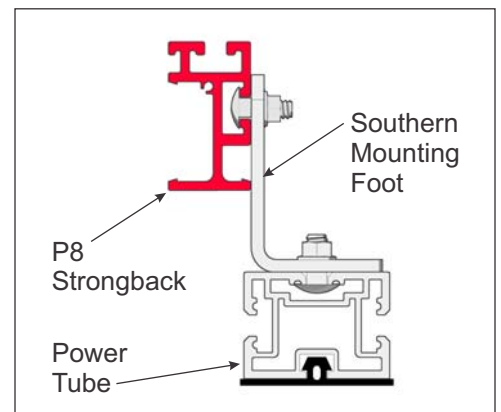

Figure 3-1: P8 Strongback Profile Orientation to South Mounting Foot

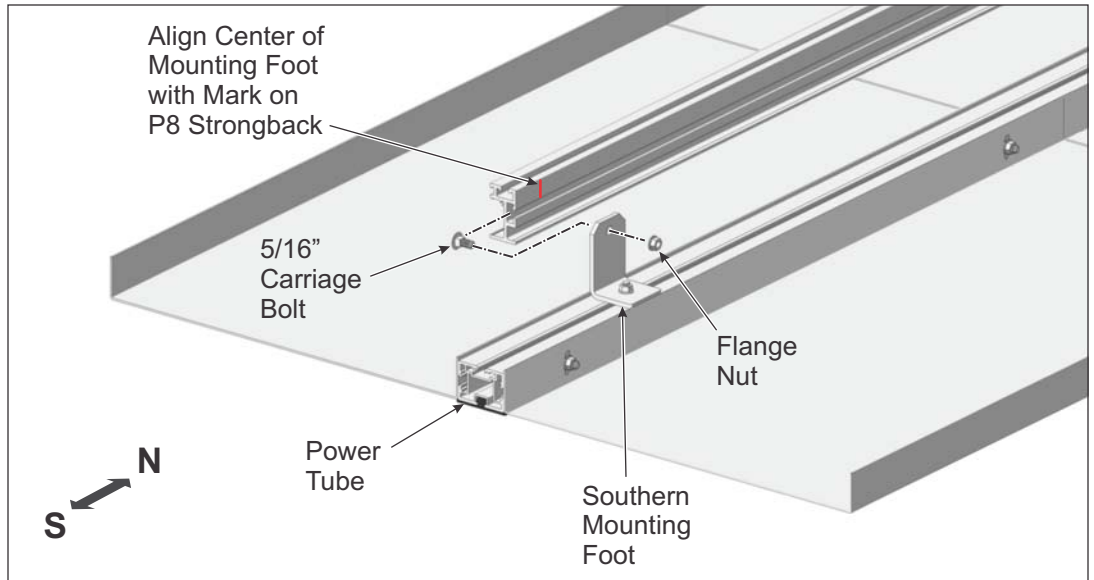

Figure 3-2: Attaching P8 Strongback to Southern Mounting Foot

Step 4: Attach Leg to P8 Strongback

These instructions cover two types of Legs, the One-Piece and the Telescoping. Both types are secured to the P8 Strongback using 5/16" x 3/4" carriage bolts and flange nuts. (See Figure 4-1)

- A. Slide 5/16" x 3/4" carriage bolt into P8 Strongback, aligning bolt with the previously made 14-inch mark on the P8 Strongback.
- B. Align mounting hole of Leg to carriage bolt and secure with 5/16" flange nut. Finger tighten for now.

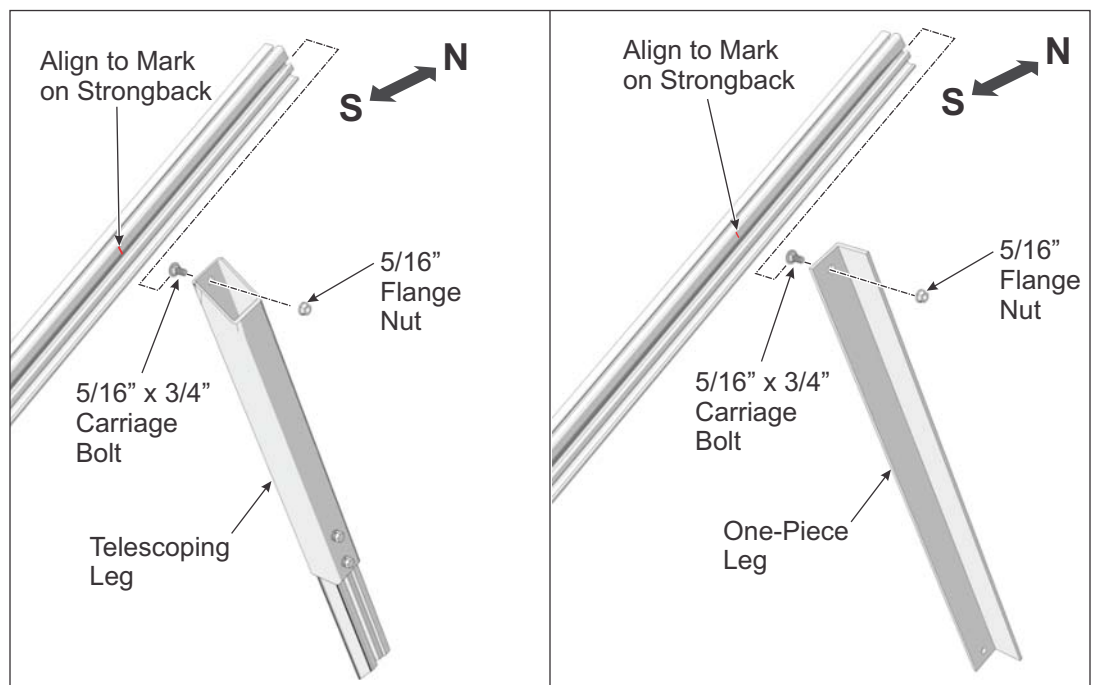

Figure 4-1: Attaching Telescoping Leg to Strongback

Step 5: Attach Leg to Northern Mounting Foot

The Leg is secured to the northern Mounting Foot using a 5/16" x 3/4" hex bolt and flange nut. On the Telescoping Leg, it may be necessary to loosen the two lock bolts in order to extend or shorten the leg as needed to align the mounting hole of the leg with the hole of the northern Mounting Foot. (See Figure 5-1)

- A. Raise the northern end of the P8 Strongback and align the mounting hole of the Leg to the hole of the northern Mounting Foot. Secure with 5/16" x 3/4" hex bolt and flange nut.
- B. Check that the upper position of the Leg did not shift from the 14-inch mark on the P8 Strongback. Adjust to align if needed.

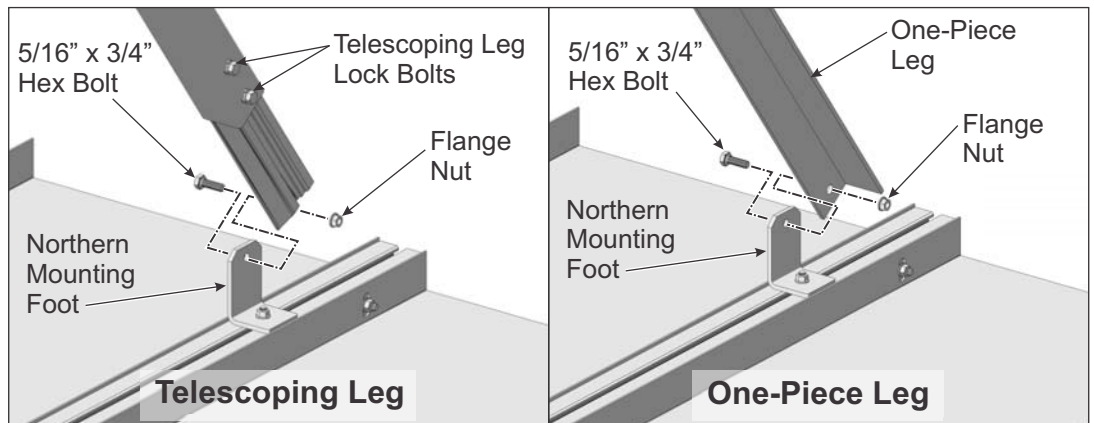

Figure 5-1: Attaching Leg to Northern Mounting Foot

Step 6: Set the P8 Strongback Tilt Angle

Starting with the site specific array tilt angle, adjust each of the P8 Strongbacks to match this angle. Adjust the tilt angle via the Telescoping Leg. (See Figure 6-1)

- A. Loosen the two Telescoping Leg Lock Bolts.
- B. Depending on the required adjustment, lengthen or shorten the Telescoping Leg until the P8 Strongback tilt angle is achieved.
- C. Tighten the two Telescoping Leg Lock Bolts. **Torque to 14-16 ft.-lbs.**
- D. Continue in this manner to set the tilt angle on the remaining P8 Strongback.

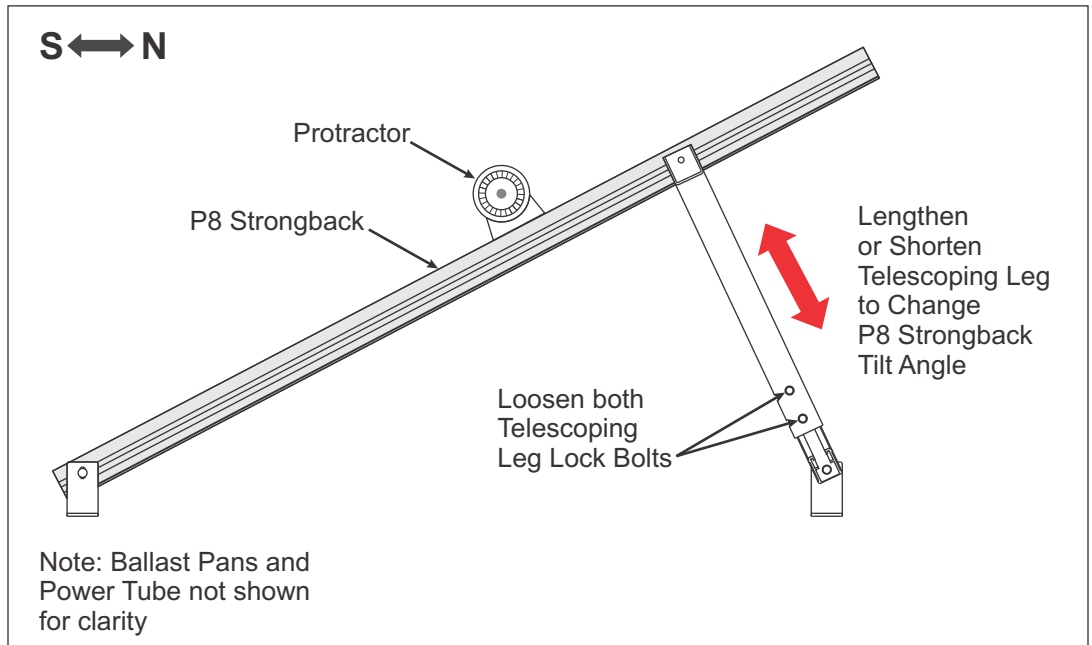

Figure 6-1: Setting P8 Strongback Tilt Angle

Step 7: Return and Tighten/Torque Hardware as Follows

- Flange Nuts securing P8 Strongback to Mounting Foot: **Torque to 14-16 ft.-lbs.**
- Flange Nuts securing Telescoping Leg to P8 Strongback: **Torque to 14-16 ft.-lbs.**
- Hardware securing Telescoping Leg to Mounting Foot: **Torque to 14-16 ft.-lbs.**

Step 8: Attach Rail Brackets to P8 Strongbacks

Rail Brackets are attached to the P8 Strongbacks and secured with 5/16” x 3/4” carriage bolts and flange nuts. There are two Rail Brackets per P8 Strongback.

The N-S span of the Rail Brackets along the P8 Strongback is dependent on the type/size of module being used. If the module manufacturer has provided specific clamping locations, use those specifications; if none are specified by the manufacturer, use a factor of 60-percent of the module length to determine the N-S span of the Rail-to-Rail brackets. The southern edge of the module aligns to the southern end of the P8 Strongback. (See Figure 8-1)

Once the span is determined, measure and mark the positions of the Rail Brackets on each of the P8 Strongbacks.

NOTE:

Use care in aligning the Rail Brackets from one P8 Strongback to the next. This will greatly assist in the installation of the P8 Power Rails.

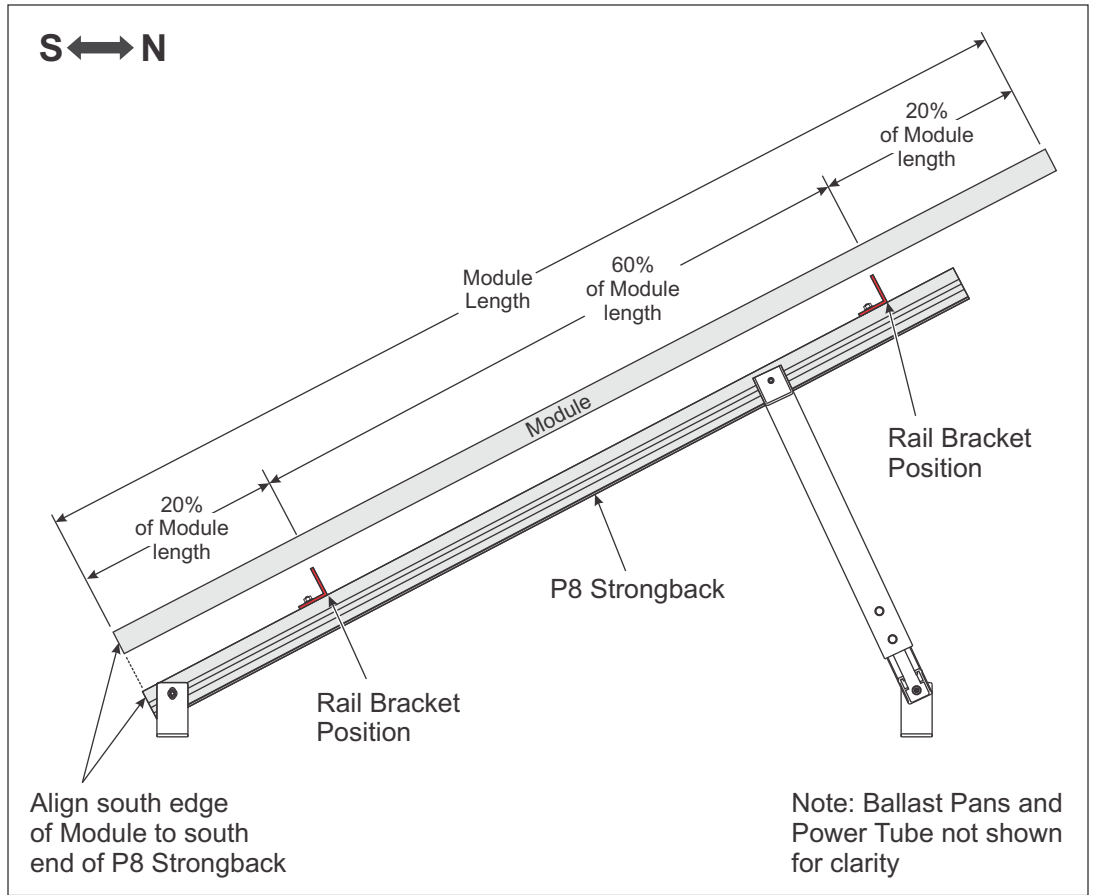

Figure 8-1: Positioning Rail Brackets on P8 Strongback

Align the Rail Brackets to the marks on the P8 Strongback. (See Figure 8-2)

- A. Slide 5/16" x 3/4" carriage bolt into the P8 Strongback.
- B. Align Rail Bracket to carriage bolt and secure with 5/16" flange nut. **Torque to 14-16 ft.-lbs.**

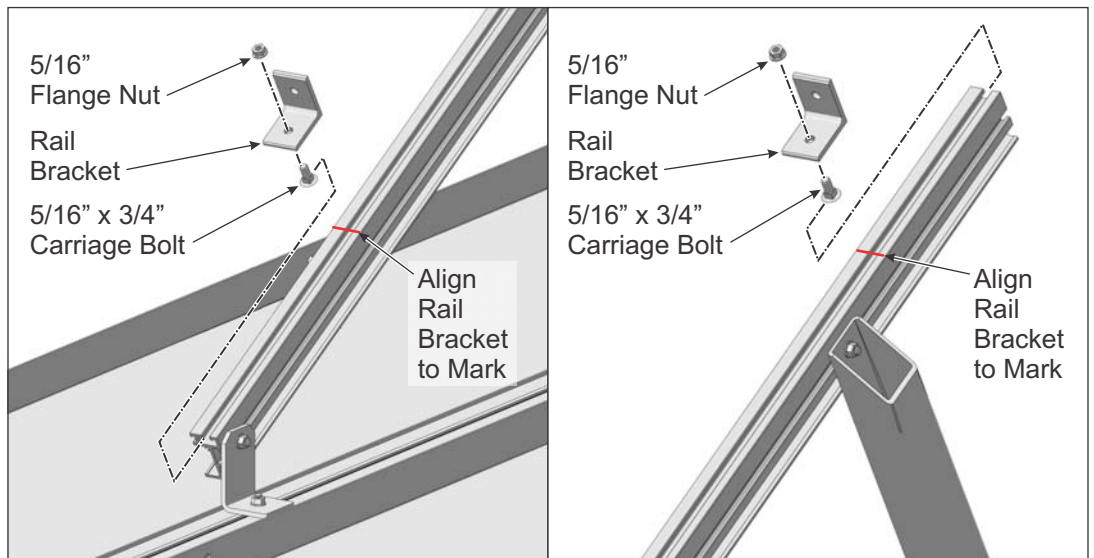

Figure 8-2: Attaching Southern and Northern Rail Brackets on P8 Strongback

Step 9: Position and Align the Assembled Units

Position each of the assembled units, i.e., that which has been assembled to this point. Position the units on the roof in their final positions - once the Ballast Pans have been populated with ballast, the assembled units will no longer be moveable.

The east/west spacing between the Power Tubes is set as follows: Using the length of the P8 Power Rail as a gauge, calculate a dimension equal to 25% of the total length. This dimension is the east/west space between the Power Tubes. (See Figure 9-1)

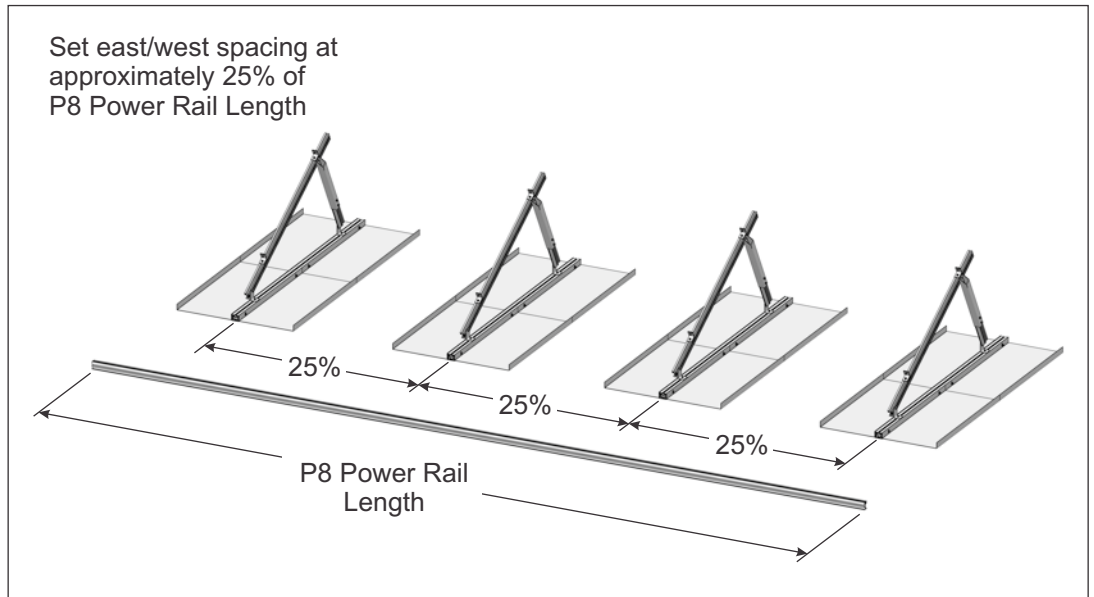

Figure 9-1: Establishing East/West Spacing

Step 10: Installing P8 Power Rails

P8 Power Rails attach to the Rail brackets using 5/16" x 3/4" turn bolts and flange nuts. While installing, pay close attention to the orientation between the P8 Power Rail and the Rail Brackets. (See Figure 10-1)

- A. Position the southern P8 Power Rail to the north side of the Rail Brackets with the P8 Power Rail profile in the same orientation shown in Figure 10-1.
- B. Insert and twist one 5/16" x 3/4" turn bolt into the P8 Power Rail at each location of Rail Brackets along the P8 Power Rail.
- C. Align and pass each turn bolt through its respective Rail Bracket and secure with 5/16" flange nuts. **Torque all at 14-16 ft.-lbs.**

Install the northern Power Rail in the same manner.

NOTE:
Squaring of the Modules to Rails saves time and simplifies the assembly process.

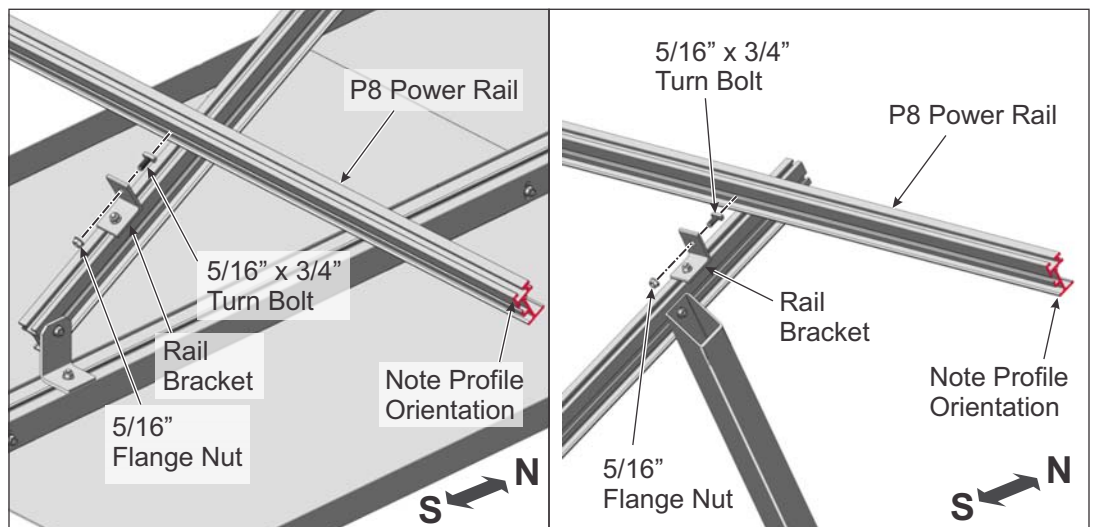

Figure 10-1: Installing Southern and Northern P8 Power Rails

NOTE:

All ballast requirements have been calculated based on uplift and drag force data gathered from full-scale wind-tunnel testing.

Block weight and size may vary based on site conditions. Please contact us for site-specific wind tunnel evaluation and block specification.

Step 11: Weighting Ballast Pans

Ballast Pans are lined with Concrete Cap Blocks specified at 4 x 8 x 16 inches (these dimensions are nominal, actual dimensions are less) each weighing a minimum of 25 lbs. to withstand 90-MPH maximum wind speeds. Different sized cap blocks may be used as long as the site specific weight requirements are met or exceeded.

Place the Concrete Cap Blocks side-by-side along each of the Ballast Pans. Line each of the Ballast Pans completely with the Blocks. (See Figure 11-1)

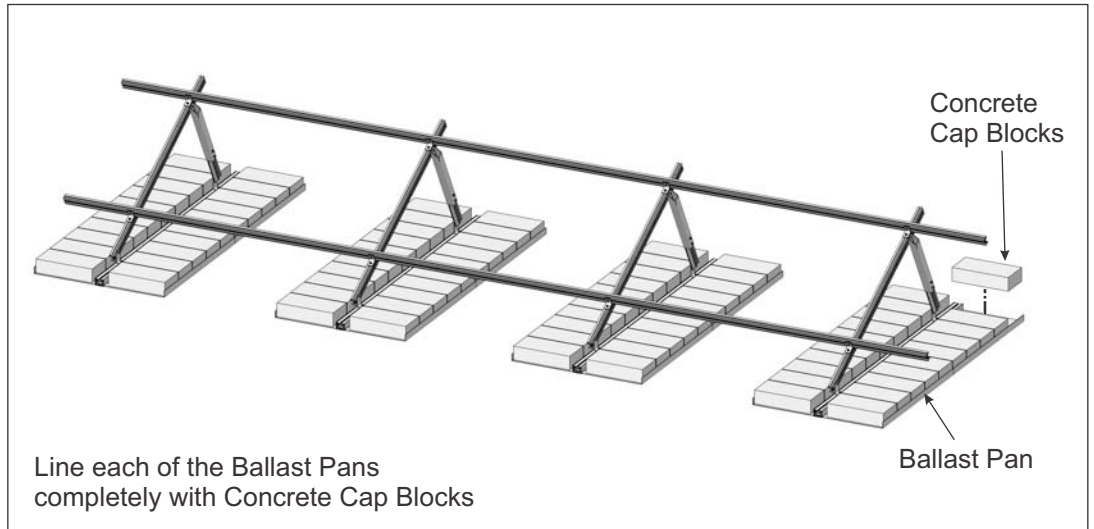

Figure 11-1: Weighting Ballast Pans with Concrete Cap Blocks

WARNING:

This is a two person activity. In addition to the difficulties associated with working on a sloped rooftop, PV Modules are heavy. One person should hold and align the modules while a second person secures modules with clamping hardware. Failure to do so could lead to serious personal injury and/or damaged components.

CAUTION:

Ballast Pans must be filled with ballast before the PV Modules are installed. Failure to do so could lead to serious personal injury and/or damaged components if heavy winds were to develop.

WARNING:

Modules must be held in place until they are secured at all four points with clamping hardware. Failure to do so could lead to serious personal injury and/or damaged components.

Step 12: Installing PV Modules to Power Rails with Module Clamps

PV Modules are secured to the P8 Power Rail using Mid Clamps and End Clamps, both use 5/16" bolts and flange nuts.

These instructions include three options of clamping hardware, they are "Universal End Clamp" (step B1), "Standard End Clamp" (step B2), and "RAD Clamps" (step B3).

Start with an exterior PV Module.

- A. Place the exterior PV Module on top of the P8 Power Rails, aligning the south end to the south end of the P8 Strongback lengthwise. Use a square to square-up the Module to the P8 Power Rails.
- B1. For use with "**Universal End Clamps**": Position Universal Clamp underneath module with notches facing the outside edge of the module, and the rail centered between the forks of the clamp. Slide the clamp notches towards module flange until the flange bottoms out in the notches. Tighten 5/16" bolt on bottom of universal end clamp. **Torque to 14-16 ft.-lbs.** Repeat for both end clamps. (See Figure 12-1)

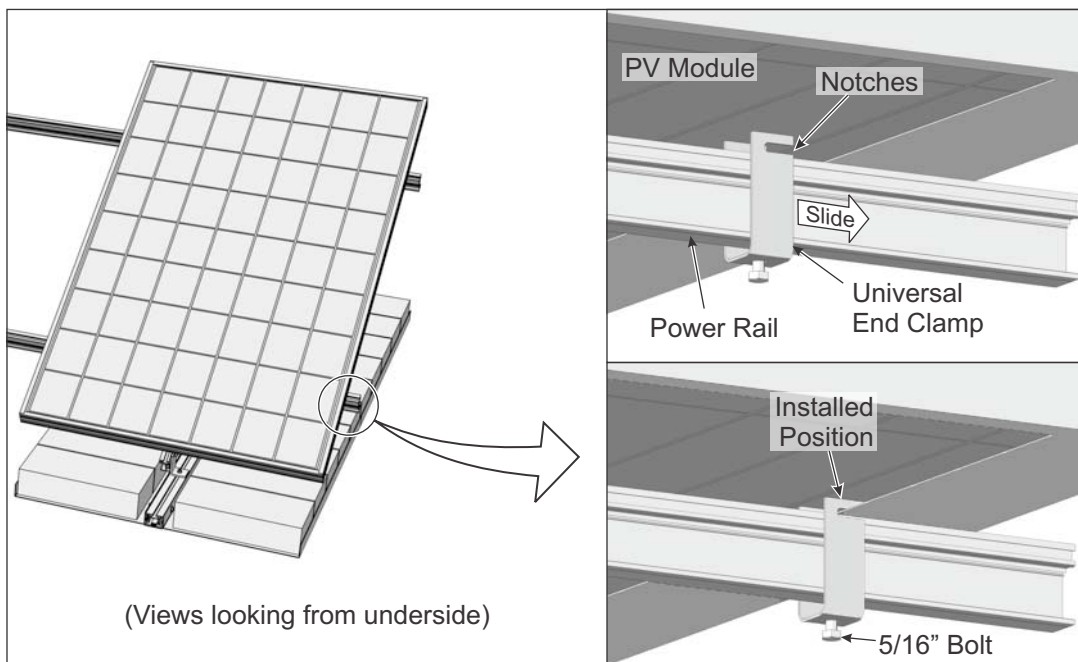

Figure 12-1: Installing PV Modules using Universal End Clamp

B2. For use with “**Standard End Clamps**”: Standard End Clamps must be installed as shown in Figure 12-2.

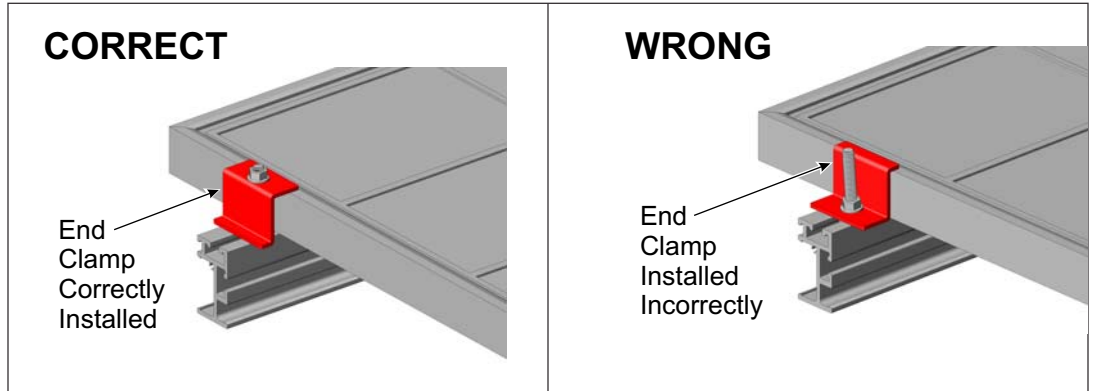

Figure 12-2: Correct and Wrong methods of installing Standard End Clamp

Insert one 5/16” x 2, 2-1/4, 2-1/2 or 2-3/4” carriage bolt into the top slot of the P8 Power Rail. Push the bolt until flush with the outer edge of the module frame. Position End Clamp with hole facing upwards and center hole over bolt. Seat End Clamp over bolt flush with module frame. Thread 5/16” flange nut onto End Clamp and tighten. When desired alignment is obtained, tighten the nut and End Clamp. **Torque End Clamps to 14-16 ft.-lbs.** (See Figure 12-3)

NOTE:
Hardware is dependent on particular features and system design. Therefore, it may appear different from these instructions.

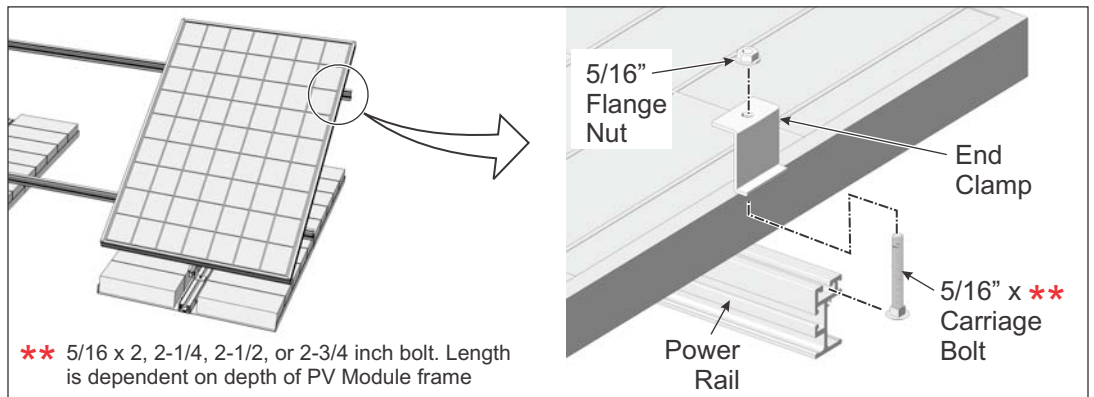

Figure 12-3: Installing PV Modules using Standard End Clamp

NOTE:

If using standard 5/16" carriage bolts for Mid Clamps, they must be inserted into the Power Rail before installing interior PV Modules.

If using RAD hardware, they can be inserted anytime at any position along the Power Rail.

B3. For use with “**RAD Hardware**”: The process is much the same as step B2. The difference is RAD bolts can be inserted anywhere along the P8 Power Rail, not just the ends of the rail as shown in Figure 12-3.

Although this step demonstrates installing a *Mid Clamp*, the procedure for an *End Clamp* is much the same when using RAD hardware.

Insert RAD bolt into P8 Power Rail and rotate 90-degrees to lock into rail. Install module clamp (End or Mid Clamp) onto bolt by aligning the flat portion of the clamp with that of the bolt. Thread 5/16" flange nut onto clamp and tighten. When desired alignment is obtained, tighten the nut and end clamp. **Torque End Clamps to 14-16 ft.-lbs.** (See Figure 12-4)

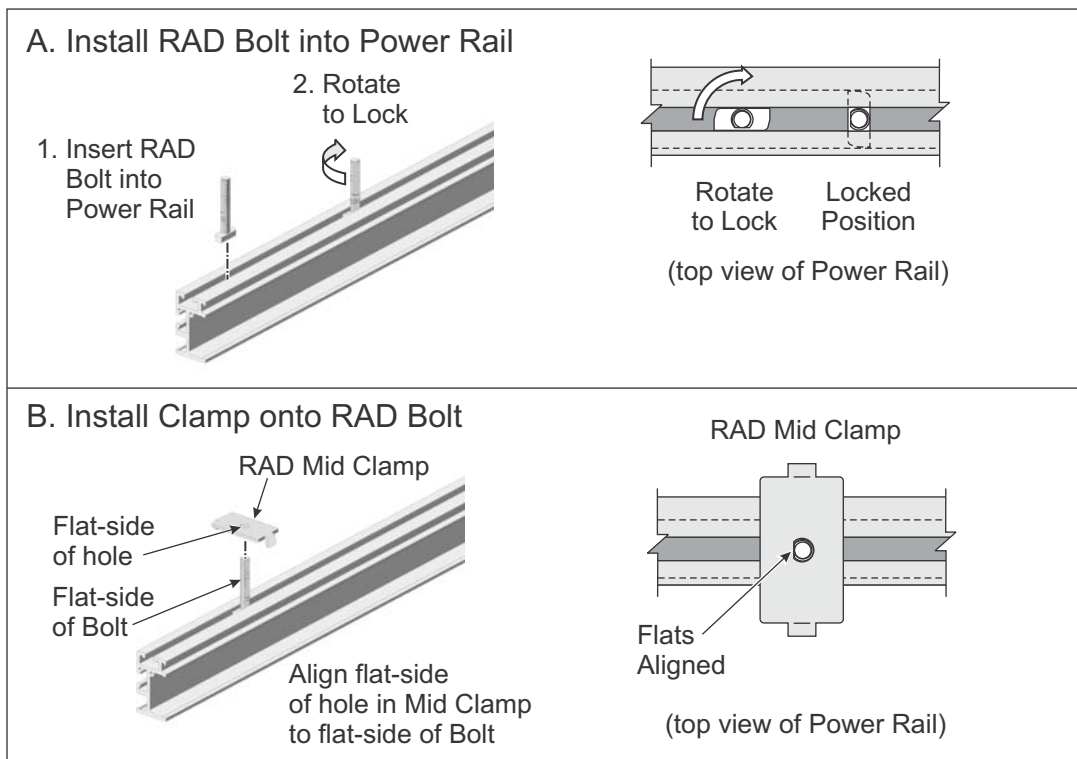

Figure 12-4: Installing PV Modules using RAD Hardware

Installing interior PV Modules.

- A. Before placing an interior PV Module onto the Power Rails, first insert 5/16" x 2, 2-1/4, 2-1/2, or 2-3/4" carriage bolts (bolt length is dependent on depth of PV Module frame) into the Module Rail, sliding the bolts inward adjacent to the previously installed exterior PV Module.
- B. Position the Mid Clamp fasteners flush with the outer edge of the installed module frame, opposite the end clamps. (See Figure 12-5)

WARNING:

Be certain that all hardware has been re-tightened and torqued to the stated values. Failure to do so could lead to serious personal injury and/or damaged components and property.

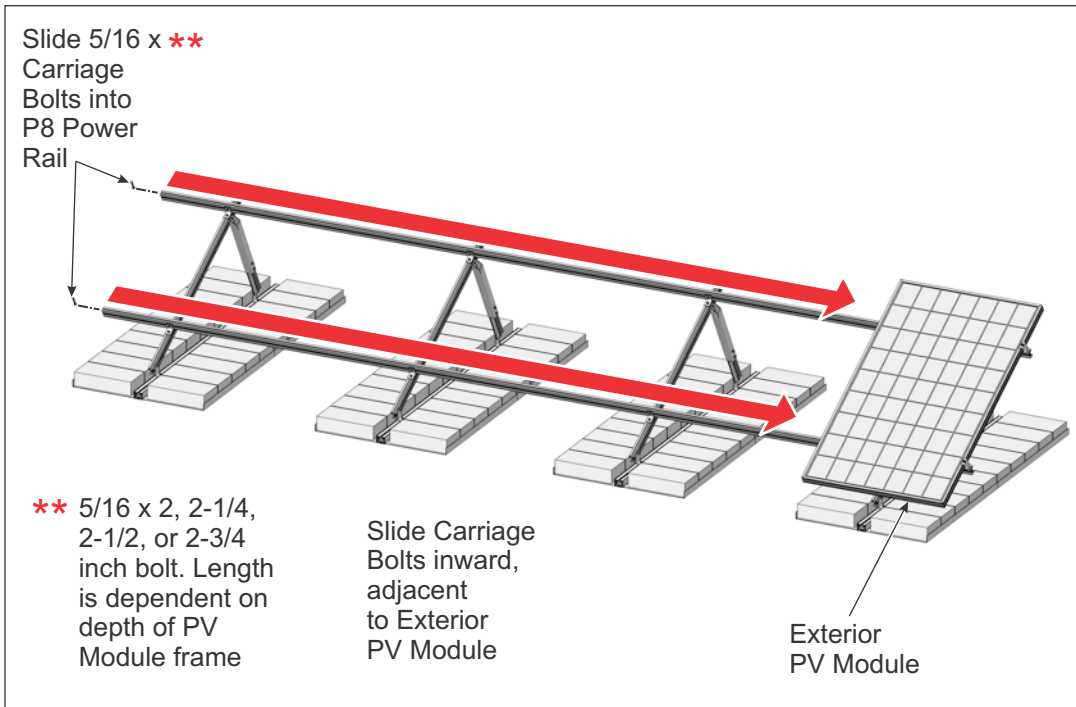

Figure 12-5: Inserting Mid Clamp Hardware into P8 Power Rail

WARNING:

This is a two person activity. In addition to the difficulties associated with working on a sloped rooftop, PV Modules are heavy. One person should hold and align the modules while a second person secures modules with clamping hardware. Failure to do so could lead to serious personal injury and/or damaged components.

- C. Place the interior PV Module onto the Power Rails, aligning it (top to bottom) with the previously installed exterior PV Module. Position it adjacent to the 5/16" bolts and the previously installed exterior PV Module.
- D. Use a square to square-up the Module to the Power Rails.
- E. Install one Mid Clamp on each of the 5/16" bolts that are between each of the interior PV Modules. Be sure that the tabs of the Mid Clamp rest between the two Modules and the Modules are butted up against the Mid Clamp tabs (see figure 12-6). Secure each of the Mid Clamps with a 5/16" flange nut. **Torque Mid Clamps to 14-16 ft.-lbs.** (See Figures 12-6 and 12-7)

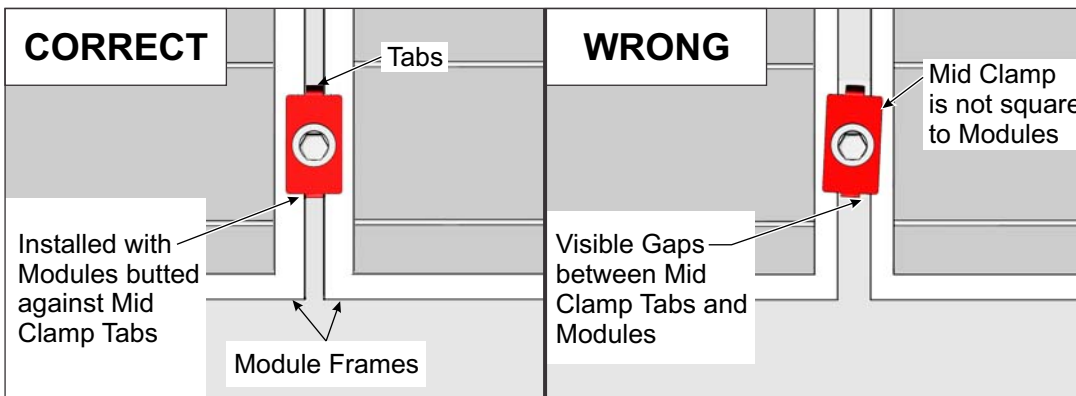

Figure 12-6: Correct and Wrong methods of installing Standard Mid Clamp

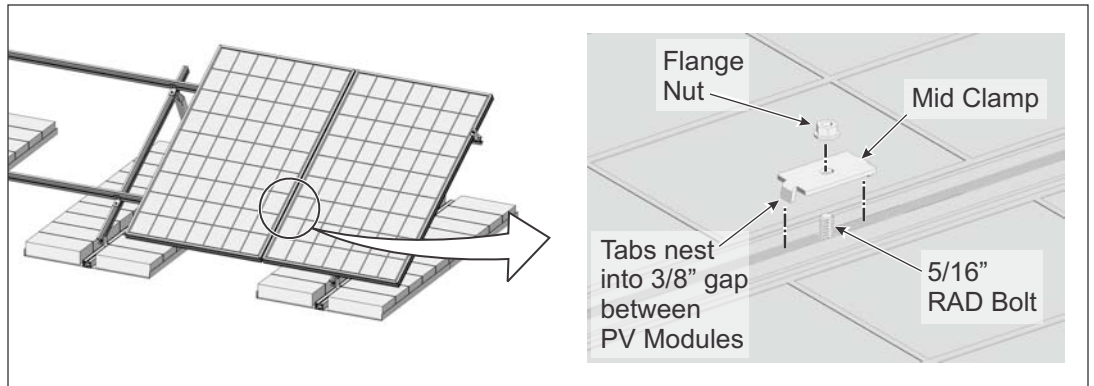

Figure 12-7: Installing Mid Clamps

Step 13: Adjusting Tilt Angle with Telescoping Legs

This step addresses the need to modify the tilt from that which was set in Step 7 earlier. The Telescoping legs are designed to easily adjust the tilt angle of an array, even after the array is fully assembled. It is recommended that this procedure be done by a minimum of three people. After loosening specific hardware, the full array pivots from the southern Mounting Feet. (See Figure 13-1)

Use caution when loosening hardware to avoid disengaging from their locations. Loosen just enough to allow components to rotate freely. (See Figure 13-2)

- A. First, loosen the hardware attaching the Strongbacks to the Mounting Feet.
- B. As two people hold and support the array from the backside, the third person loosens the hardware at both ends of the Telescoping legs.
- C. Now loosen the Telescoping leg lock bolts.
- D. Lift/push the array to the desired tilt angle and hold in place.

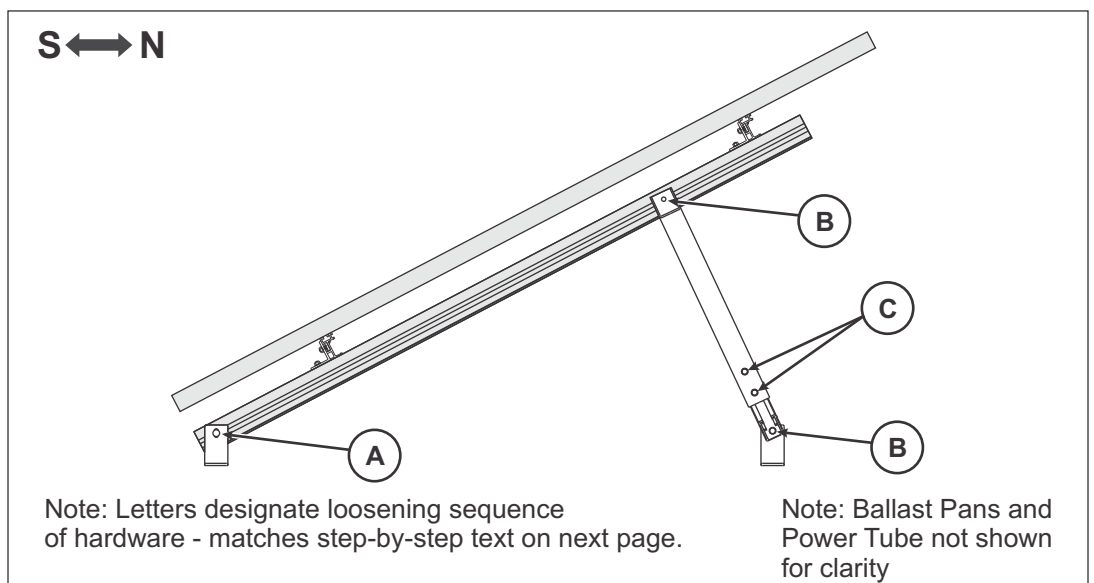

Figure 13-1: Adjusting Tilt Angle

WARNING:

It's very important to support the weight of the array during this procedure. A minimum of two people should be used to hold and support the array while a third person loosens and re-tightens the hardware. Failure to do so could lead to serious personal injury and/or damaged components and property.

WARNING:

Be certain that all Flange Nuts on End and Mid Clamps are tightened and torqued to the stated values. Failure to do so could lead to serious personal injury and/or damaged components and property.

E. Re-tighten and torque hardware as follows:

1. Two Telescoping Leg lock bolts: **Torque to 14-16 ft.-lbs.**
2. Flange Nuts securing Legs to Strongback: **Torque to 14-16 ft.-lbs.**
3. Hardware securing Legs to Mounting Feet: **Torque to 14-16 ft.-lbs.**
4. Flange Nuts securing P8 Strongbacks to Mounting Feet: **Torque to 14-16 ft.-lbs.**

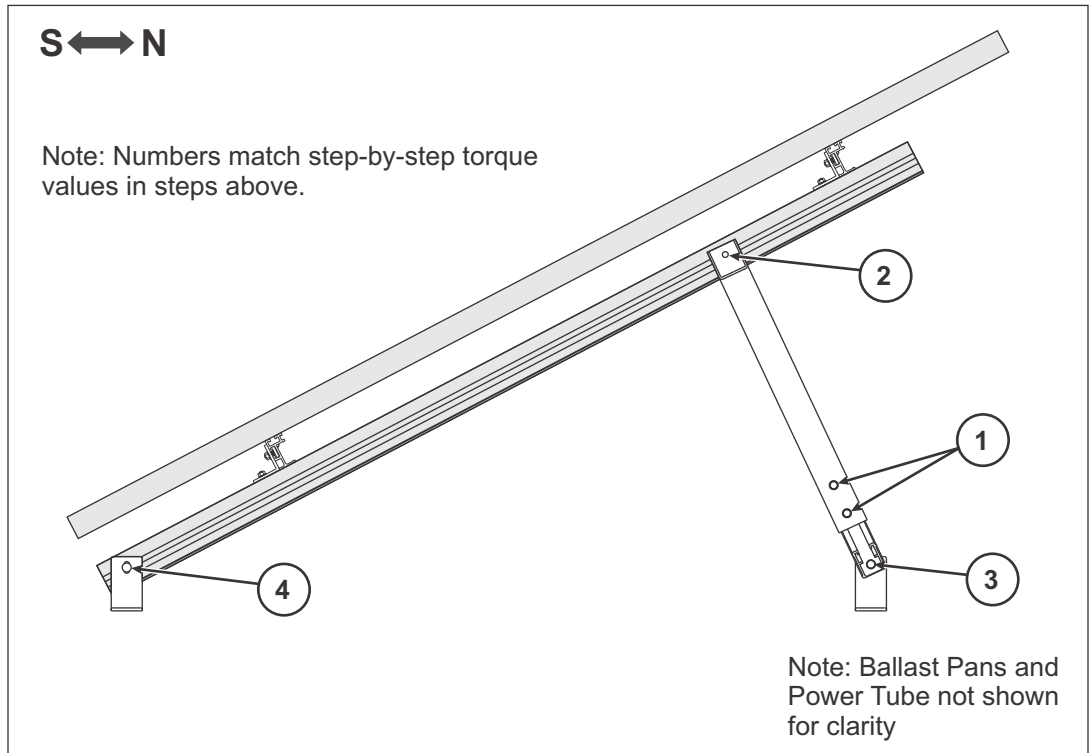

Figure 13-2: Re-tighten and Torque Hardware



4000-B Vassar Drive NE
Albuquerque, New Mexico 87107
USA

Telephone: 800.260.3792
Fax: 505.889.3548
Web Site: www.DPWSolar.com
E-mail: info@power-fab.com

© 2011 Preformed Line Products
PCN 111611-1
Version 1, Rev A